

IE-352

# Manufacturing Processes – 2

FALL - 2015

Lecture (3)

## Coordinate Dimensioning and Tolerancing

Ahmed M. El-Sherbeeney, PhD

Industrial Engineering Department  
King Saud University



# Outline

1. Introduction
2. Basic Hole System
3. Basic Shaft System
4. American National Standard Fit Tables

# Introduction - *Basic Hole and Basic Shaft Systems*

- The *Basic Hole and Basic Shaft Systems* are procedures for calculating and placing mating part dimensions and tolerance information on the drawing. This will assure that if the parts are manufactured according to the specifications on the drawing, they will fit together and function as intended.
- Four basic parameters must be known to use these systems: *Basic Size, Allowance, Hole Tolerance, and Shaft Tolerance.*
  - *Basic size is the hole or shaft at maximum material condition (MMC). All tolerance values are generated from that value.*
  - *Allowance (the intentional difference between mating parts) is the minimum clearance or maximum interference. It can be positive (clearance) or negative (interference).*

# Introduction - *Basic Hole and Basic Shaft Systems*

## BASIC HOLE SYSTEM – *Allowance based on the hole at MMC*

1. The basic size is always equal to the *minimum hole size (Hole MMC)*.
2. *Subtract the allowance* from the basic size to get the *maximum shaft size (Shaft MMC)*.
3. Apply the appropriate tolerances to the hole and to the shaft (Hole & Shaft *lower material condition* (LMC)).

## BASIC SHAFT SYSTEM – *Allowance based on the shaft at MMC*

1. The basic size is always equal to the *maximum shaft size*.
2. *Add the allowance* to the basic size to get the *minimum hole size*.
3. Apply the appropriate tolerances to the shaft and the hole.

# BASIC HOLE SYSTEM

# Basic Hole System

Using the *Basic Hole System* and the following data, complete the drawing by placing the appropriate dimensions on both the shaft and the hole.

Nominal Size =  $9/16''$

Allowance =  $.0006$

Shaft Tolerance =  $.0009$

Hole Tolerance =  $.0010$

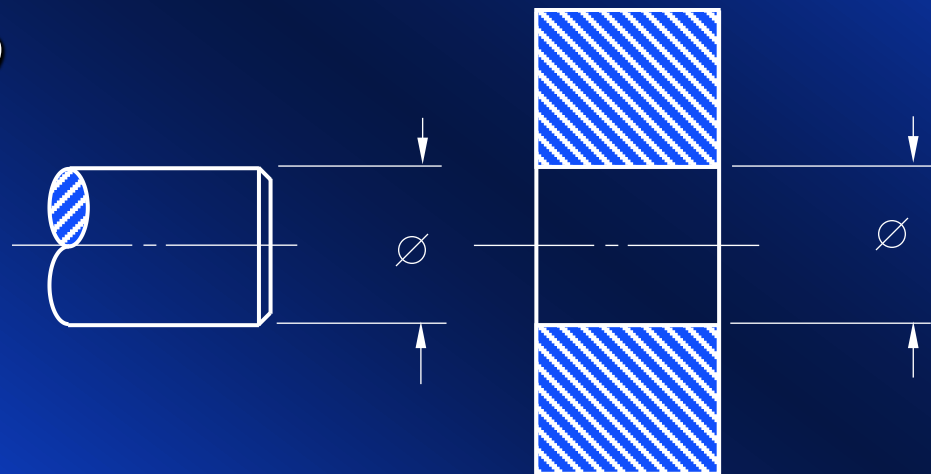

# Basic Hole System

The basic size is determined by converting the nominal size into its decimal equivalent. The basic hole system always establishes the basic size as the minimum hole size. Remember, the smallest size limit *always* goes on the bottom in a stacked limits form.

Basic Size = .5625  
Allowance = .0006  
Shaft Tolerance = .0009  
Hole Tolerance = .0010

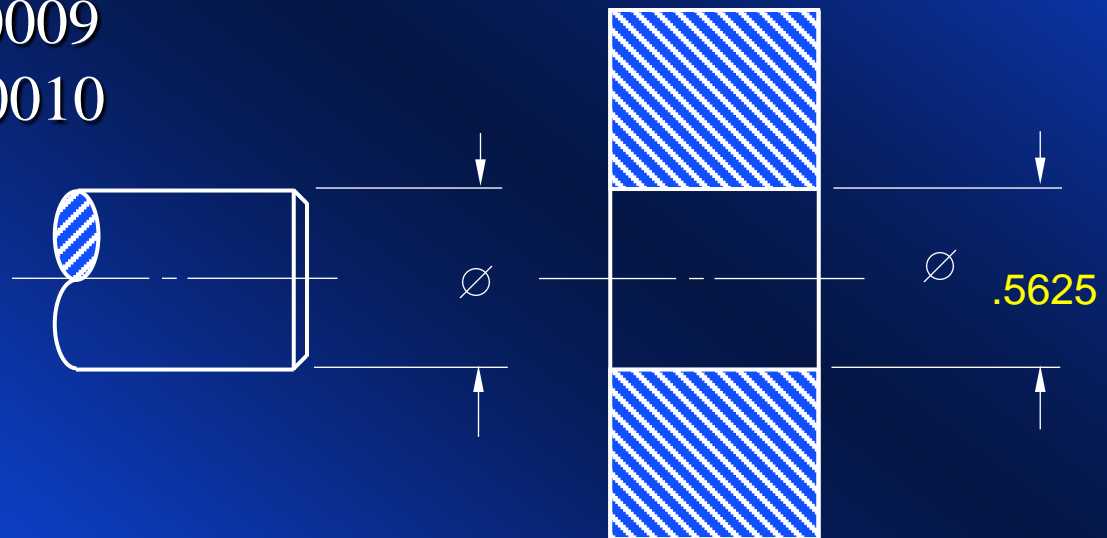

# Basic Hole System

Subtract the *allowance* from the basic size to obtain the maximum shaft size (Shaft MMC). Place the value as the upper limit of the shaft dimension.

Basic Size = .5625

Allowance = .0006

Shaft Tolerance = .0009

Hole Tolerance = .0010

Shaft MMC

.5625	Basic Size
<u>-.0006</u>	Allowance

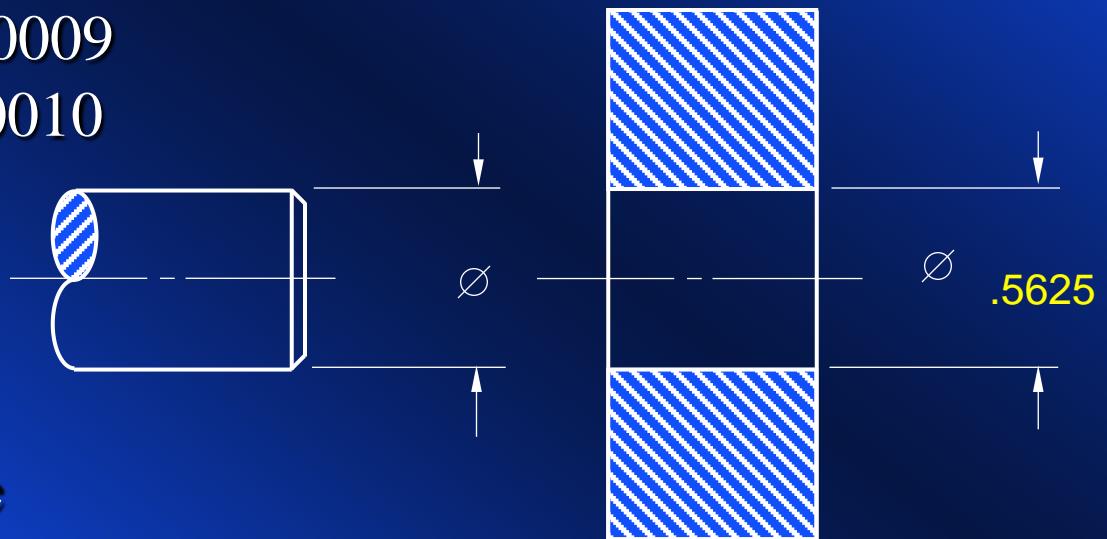



# Basic Hole System

Subtract the *allowance* from the basic size to obtain the maximum shaft size (Shaft MMC). Place the value as the upper limit of the shaft dimension.

Basic Size = .5625

Allowance = .0006

Shaft Tolerance = .0009

Hole Tolerance = .0010

Shaft MMC

.5625	Basic Size
<u>-.0006</u>	Allowance
.5619	Shaft MMC

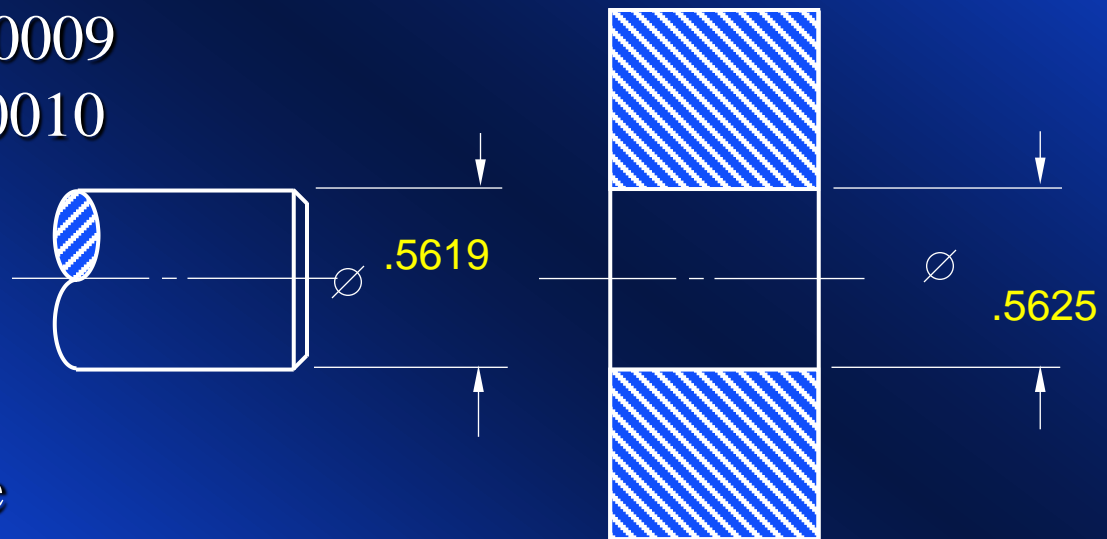

# Basic Hole System

Apply the *tolerances* to both the hole and the shaft to complete the dimensions; *add* the hole tolerance to the hole lower limit, and *subtract* the shaft tolerance from the shaft upper limit. Do the arithmetic and apply the values.

Basic Size = .5625  
 Allowance = .0006  
 Shaft Tolerance = .0009  
 Hole Tolerance = .0010

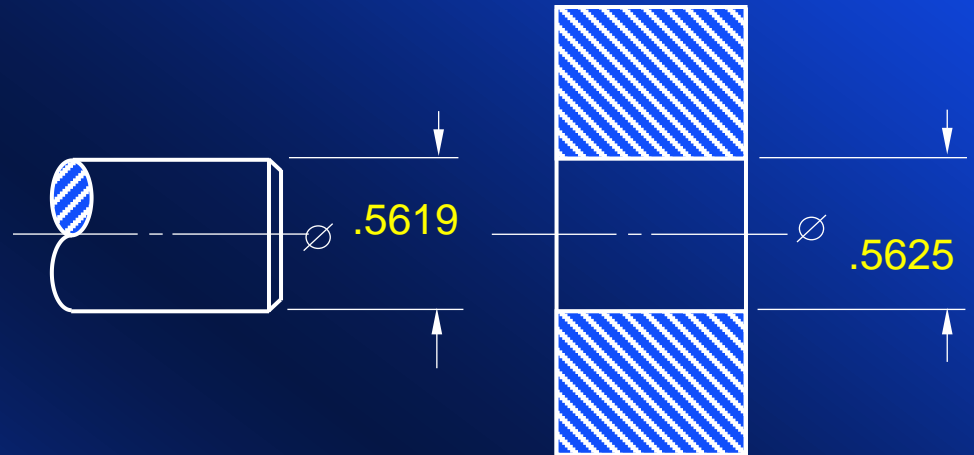

Shaft MMC		Shaft	Hole
.5625	Basic Size	.5619	.5625
<u>-.0006</u>	Allowance	<u>-.0009</u>	<u>+.0010</u>
.5619	Shaft MMC		

# Basic Hole System

Apply the *tolerances* to both the hole and the shaft to complete the dimensions; *add* the hole tolerance to the hole lower limit, and *subtract* the shaft tolerance from the shaft upper limit. Do the arithmetic and apply the values.

Basic Size = .5625  
 Allowance = .0006  
 Shaft Tolerance = .0009  
 Hole Tolerance = .0010

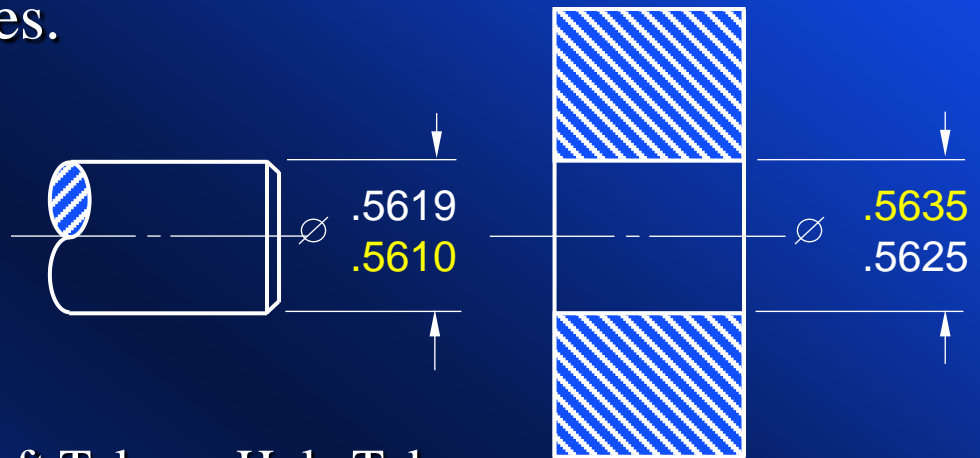

Shaft MMC		Shaft Tol	Hole Tol
.5625	Basic Size	.5619	.5625
<u>-.0006</u>	Allowance	<u>-.0009</u>	<u>+.0010</u>
.5619	Shaft MMC	.5610	.5635

Shaft

-.0006

Hole

+.0010

Values Referenced to Basic Size:  $\varnothing .5625$   $-.0015$

$\varnothing .5625$   $-.0000$

# Basic Hole System

For the values of the hole-shaft system given below, find the hole and shaft sizes using the basic hole system. Express the results in reference to the basic size and in the stacked format.

Basic Size =  $1\text{-}1/8''$

Allowance =  $.0025$

Shaft Tolerance =  $.0015$

Hole Tolerance =  $.0020$

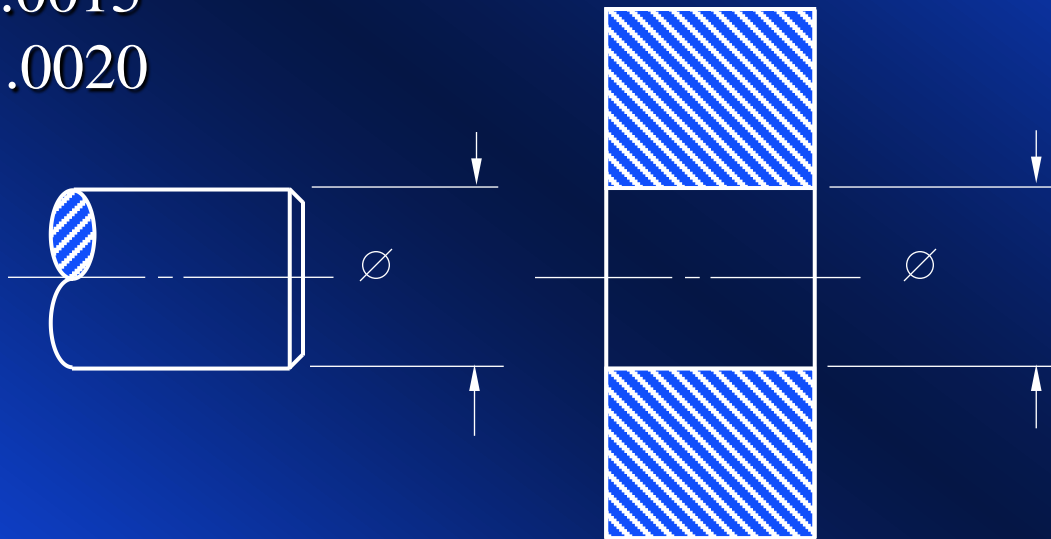

# Basic Hole System

Nominal Size =	1-1/8"	Hole		Shaft
Basic Size =	1.1250	1.1250	Basic Size	1.1225
Allowance =	.0025	<u>-.0025</u>	Allowance	<u>-.0015</u>
Shaft Tolerance =	.0015	1.1225	Max Shaft	1.1210
Hole Tolerance =	.0020			

	Shaft		Hole
Values Referenced to Basic Size: $\varnothing$ 1.1250	-0.0025		+0.0020
	-0.0040	$\varnothing$ 1.1250	-0.0000

Values expressed in  
The stacked format:

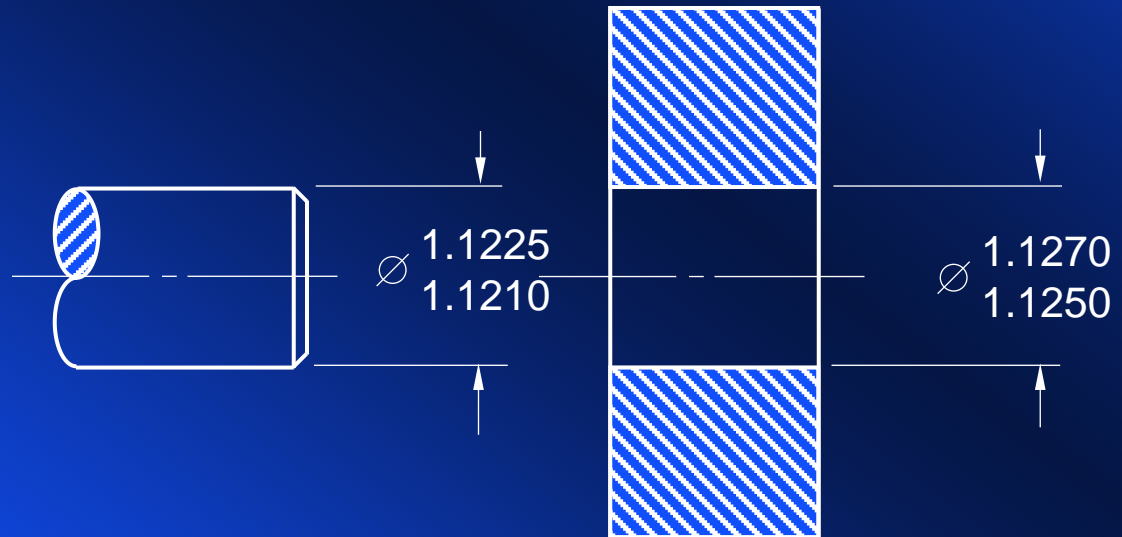

# BASIC SHAFT SYSTEM

# Basic Shaft System

Using the *Basic Shaft System* and the following data, complete the drawing by placing the appropriate dimensions on both the shaft and the hole.

Nominal Size =  $9/16''$   
Allowance =  $.0004$   
Shaft Tolerance =  $.0008$   
Hole Tolerance =  $.0010$

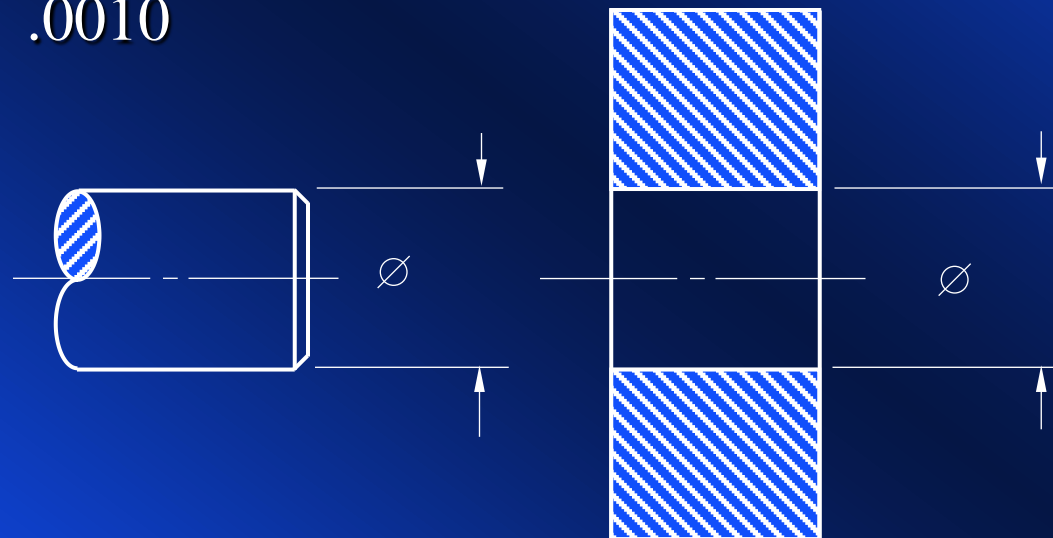

# Basic Shaft System

The basic shaft system establishes the basic size as the maximum shaft size. Remember, the upper size limit *always* goes on top in a stacked tolerance expression.

Nominal Size =  $9/16''$   
Basic Size =  $.5625$   
Allowance =  $.0004$   
Shaft Tolerance =  $.0008$   
Hole Tolerance =  $.0010$





# Basic Shaft System

The minimum hole size (Hole MMC) is obtained by *adding* the allowance to the basic shaft size. Do the addition and place the dimension as the lower limit of the hole size.

Nominal Size =  $9/16''$   
Basic Size = .5625  
Allowance = .0004  
Shaft Tolerance = .0008  
Hole Tolerance = .0010

Hole MMC

$$\begin{array}{r} .5625 \\ +.0004 \\ \hline .5629 \end{array}$$

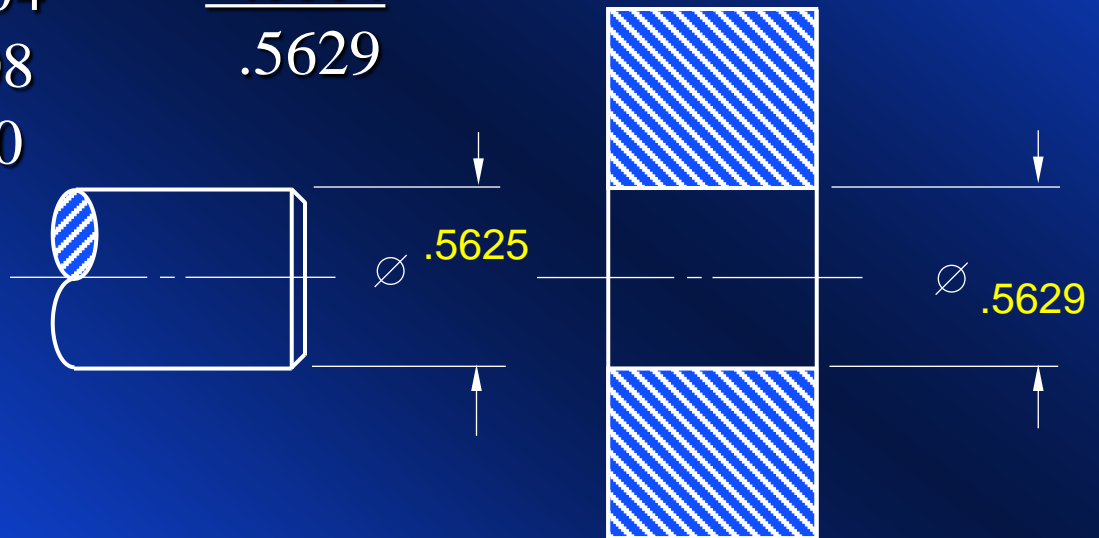

# Basic Shaft System

The process is completed by applying the tolerances to the respective components by subtracting the shaft tolerance from the shaft upper limit, and adding the hole tolerance to the hole dimension lower limit. Apply your results to the drawing.

Nominal Size =	9/16"	Shaft	Hole
Basic Size =	.5625	.5625	.5629
Allowance =	.0004	<u>-.0008</u>	<u>+.0010</u>
Shaft Tolerance =	.0008	.5617 Shaft LMC	.5639 Hole LMC
Hole Tolerance =	.0010		



# Basic Hole compared to Basic Shaft System

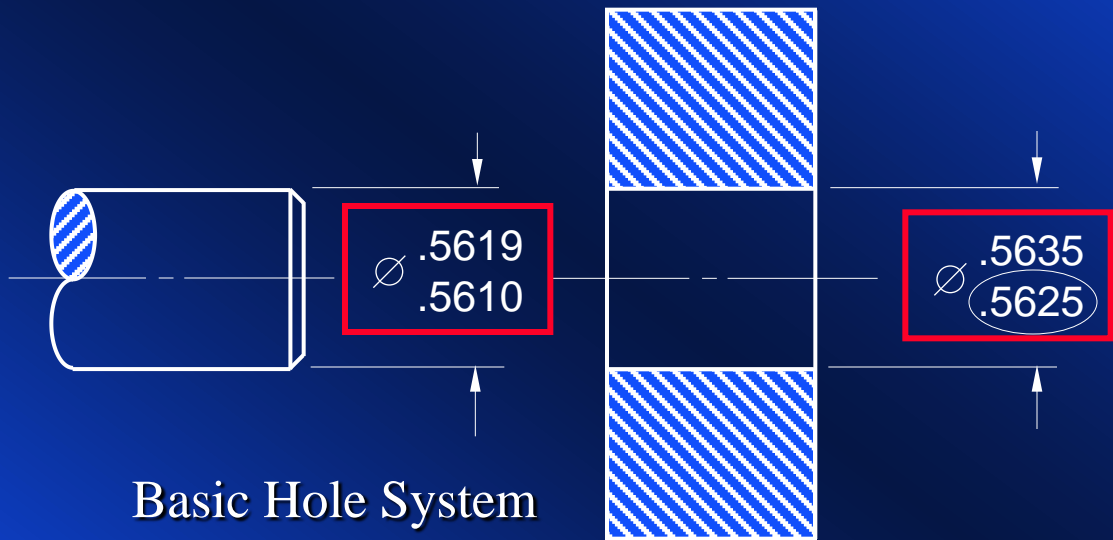

The same basic size (.5625) was used for both calculations. Compare the two results for actual sizes of the shaft and the hole.

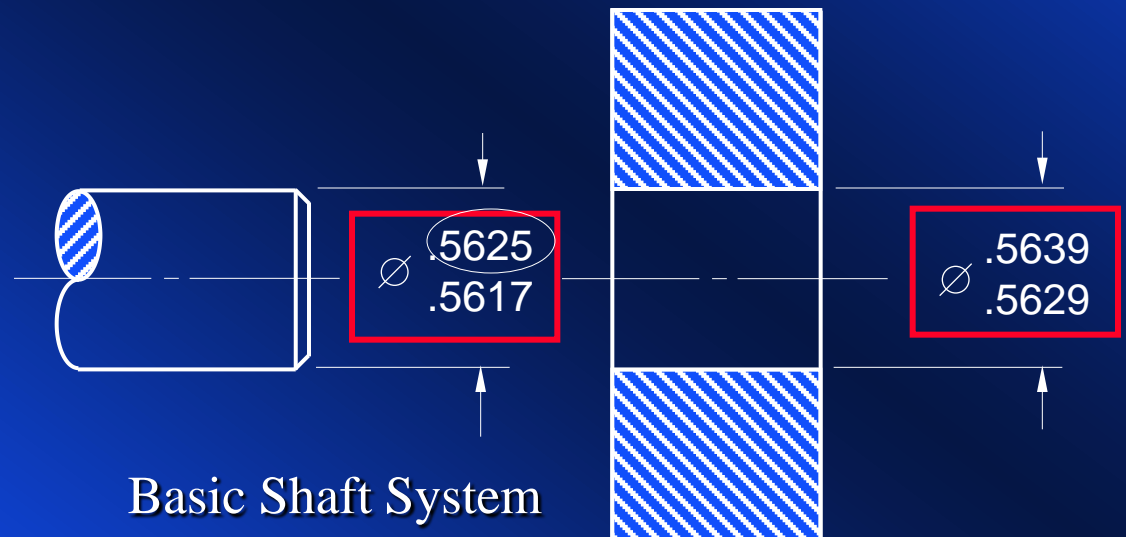

# STANDARD FITS

# American National Standard Fit Tables

- Tremendous advantages have been gained by standardizing fits, and publishing them in tables. They are the means for establishing tolerances for any given size, type, or class of fit. Each of the possible fit options within the tables are prescribed according to their intended function.
- If the designer or engineer knows the functional requirements for the fit, a match can easily be found that conforms to the specific need. The standard provides choices for a series of types and classes of fits on a unilateral hole basis such that the fit produced by mating parts in any one class will produce approximately similar performance throughout the entire range of sizes.
- The standard fit tables are consistent with the *basic hole system*. It is important that you understand how the tables themselves can be used to satisfy functional specifications and provide dimensional data to be used on engineering drawings.
- The tables reflecting standard fits between mating parts may be found in virtually any design handbook, Machinery's Handbook, and in any reputable drafting manual.

# American National Standard Fit Tables

- Standard fits fall into 3 major *categories* and 5 basic *types* of fits. Within each of these divisions there are several *classifications* of fits.
  - The first category, *Running* and *sliding* fits, for instance, has nine different classifications of this specific type of fit.
  - The second category, *Location* fits, is a broad category of standardized fits, within which there are 3 major sub-categories: *clearance*, *transition*, and *interference* fits.
  - Finally, there is a category for *Interference*, or *Force* fits consisting of 5 different classifications.
- The five divisions of standard fits are designated by letters:

<u>Category</u>	<u>Type</u>	<u>Classification</u>
Sliding	RC = Running/Sliding (Rotational or Reciprocal Motion)	Clearance Fits (RC 1 - RC 9)
Location	LC = Location Clearance Fits	(LC 1 - LC 11)
	LT = Location Transition Fits (Clearance through Interference)	(LT 1 - LT 6)
	LN = Location Interference Fits	(LN 1 - LN 3)
Force	FN = Force or Shrink Fits	(FN 1 - FN 5)

The specification is complete when the category and the classification are combined, such as RC 3 or FN 5, and coupled with a specific diameter size.

# Running and Sliding Fits\* -- American National Standard

- RC 1 Close sliding fits are intended for the accurate location of parts which must assemble without perceptible play.
- RC 2 Sliding fits are intended for accurate location, but with greater maximum clearance than class RC 1. Parts made to this fit move and turn easily but are not intended to run freely, and in the larger sizes may seize with small temperature changes.
- RC 3 Precision running fits are about the closest fits which can be expected to run freely, and are intended for precision work at slow speeds and light pressures, but are not suitable where appreciable temperature differences are likely to be encountered.
- RC4 Close running fits are intended chiefly for running fits on accurate machinery with moderate surface speeds and pressures, where accurate location and minimum play are desired.
- RC 5 } Medium running fits are intended for higher running speeds,  
RC 6 } or heavy pressures, or both.

# Running and Sliding Fits\* -- American National Standard

Basic hole system. Limits are in thousandths of an inch.

Nominal Size Range in Inches	Class RC 1			Class RC 2			Class RC 3			Class RC 4			Class RC 5			Class RC 6		
	Limits of Clearance	Standard Limits		Limits of Clearance	Standard Limits		Limits of Clearance	Standard Limits		Limits of Clearance	Standard Limits		Limits of Clearance	Standard Limits		Limits of Clearance	Standard Limits	
		Hole H5	Shaft g4		Hole H6	Shaft g5		Hole H7	Shaft f6		Hole H8	Shaft f7		Hole H8	Shaft e7		Hole H9	Shaft e8
0 - 0.12	0.1 0.45	+ 0.2 - 0	- 0.1 - 0.25	0.1 0.55	+ 0.25 - 0	- 0.1 - 0.3	0.3 0.95	+ 0.4 - 0	- 0.3 - 0.55	0.3 1.3	+ 0.6 - 0	- 0.3 - 0.7	0.6 1.6	+ 0.6 - 0	- 0.6 - 1.0	0.6 2.2	+ 1.0 - 0	- 0.6 - 1.2
0.12 - 0.24	0.15 0.5	+ 0.2 - 0	- 0.15 - 0.3	0.15 0.65	+ 0.3 - 0	- 0.15 - 0.35	0.4 1.12	+ 0.5 - 0	- 0.4 - 0.7	0.4 1.6	+ 0.7 - 0	- 0.4 - 0.9	0.8 2.0	+ 0.7 - 0	- 0.8 - 1.3	0.8 2.7	+ 1.2 - 0	- 0.8 - 1.5
0.24 - 0.40	0.2 0.6	+ 0.25 - 0	- 0.2 - 0.35	0.2 0.85	+ 0.4 - 0	- 0.2 - 0.45	0.5 1.5	+ 0.6 - 0	- 0.5 - 0.9	0.5 2.0	+ 0.9 - 0	- 0.5 - 1.1	1.0 2.5	+ 0.9 - 0	- 1.0 - 1.6	1.0 3.3	+ 1.4 - 0	- 1.0 - 1.9
0.40 - 0.71	0.25 0.75	+ 0.3 - 0	- 0.25 - 0.45	0.25 0.95	+ 0.4 - 0	- 0.25 - 0.55	0.6 1.7	+ 0.7 - 0	- 0.6 - 1.0	0.6 2.3	+ 1.0 - 0	- 0.6 - 1.3	1.2 2.9	+ 1.0 - 0	- 1.2 - 1.9	1.2 3.8	+ 1.6 - 0	- 1.2 - 2.2
0.71 - 1.19	0.3 0.95	+ 0.4 - 0	- 0.3 - 0.55	0.3 1.2	+ 0.5 - 0	- 0.3 - 0.7	0.8 2.1	+ 0.8 - 0	- 0.8 - 1.3	0.8 2.8	+ 1.2 - 0	- 0.8 - 1.6	1.6 3.6	+ 1.2 - 0	- 1.6 - 2.4	1.6 4.8	+ 2.0 - 0	- 1.6 - 2.8
1.19 - 1.97																		
1.97 - 3.15																		

\*From ANSI B4.1--1967 (R 1987).

Larger diameters and RC 7 through RC 9 not included in this presentation.



# Using the Standard Fit Tables to Assign Dimensions to Mating Parts

Using the standard fit tables, determine the limits for a nominal 9/16 (.5625) inch diameter RC 4 fit between a shaft and a hole. Place the dimensions on the drawing using stacked limits form.

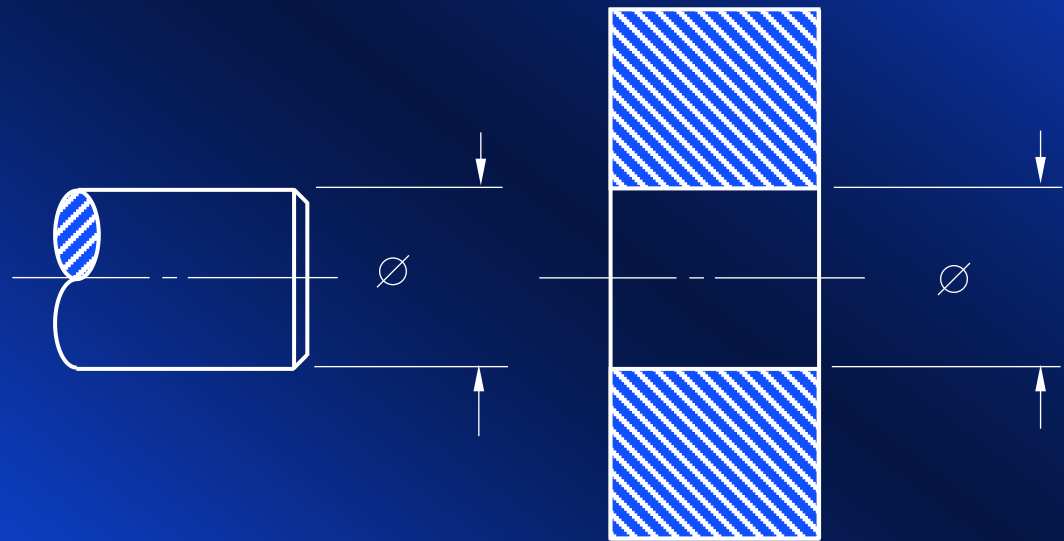

# Using the Standard Fit Tables to Assign Dimensions to Mating Parts

First, identify the size range in the left-most column in the fit table for RC fits. The row that identifies the size range that will include the designated diameter in the problem have been highlighted. Note that this column is specified in inches. All other columns in the table are specified in *thousandths* of an inch.

Nominal Size Range in Inches
0 - 0.12
0.12 - 0.24
0.24 - 0.40
<b>0.40 - 0.71</b>
0.71 - 1.19
1.19 - 1.97
1.97 - 3.15

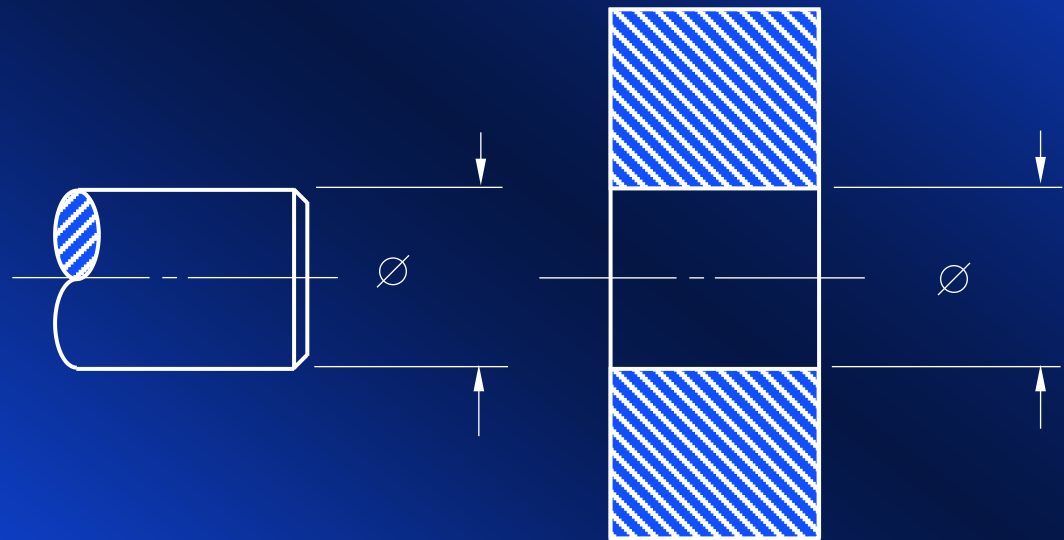

# Using the Standard Fit Tables to Assign Dimensions to Mating Parts

Next, read across the table on the row that is highlighted to identify the parameters for an RC 4 fit. Because of the lack of space, the columns for fits other than the RC 4 are excluded.

Nominal Size Range in Inches	Class RC 4			
	Limits of Clearance	Standard Limits		
		Hole H8	Shaft f7	
0 - 0.12	0.3	+ 0.6	- 0.3	
	1.3	- 0	- 0.7	
0.12 - 0.24	0.4	+ 0.7	- 0.4	
	1.6	- 0	- 0.9	
0.24 - 0.40	0.5	+ 0.9	- 0.5	
	2.0	- 0	- 1.1	
<b>0.40 - 0.71</b>	<b>0.6</b>	<b>+ 1.0</b>	<b>- 0.6</b>	
	<b>2.3</b>	<b>- 0</b>	<b>- 1.3</b>	
0.71 - 1.19	0.8	+ 1.2	- 0.8	
	2.8	- 0	- 1.6	
1.19 - 1.97				
1.97 - 3.15				

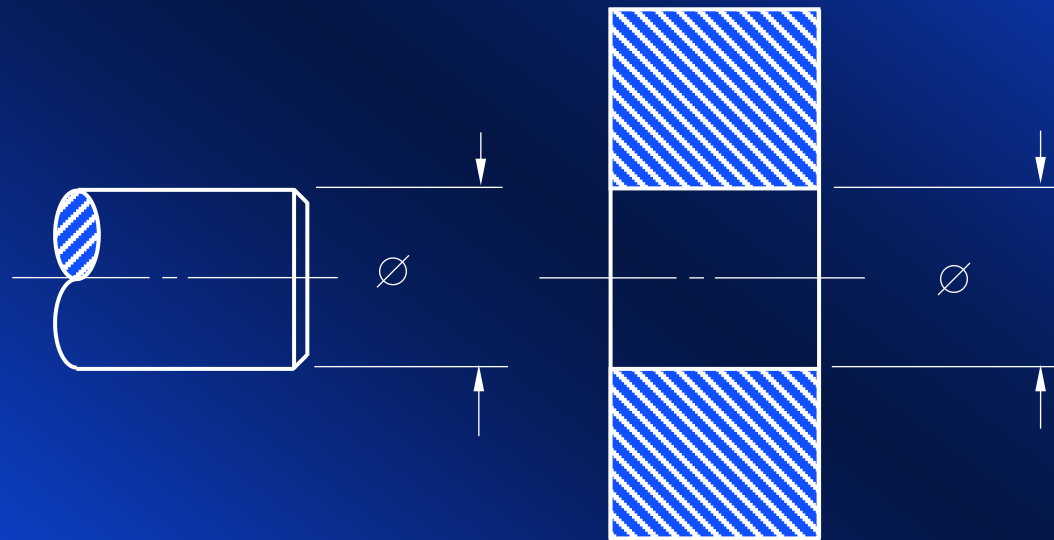

# Using the Standard Fit Tables to Assign Dimensions to Mating Parts

The first column for a class RC 4 fit establishes the *limits of clearance*. The number on top is the *allowance* at MMC. Converted to inches (by moving the decimal 3 places to the left), this number would be .0006, six tenths of one-thousandth, or six ten-thousandths. The number below (2.3) is the maximum clearance at LMC, or twenty-three ten-thousandths (.0023).

Nominal Size Range in Inches	Class RC 4		
	Limits of Clearance	Standard Limits	
		Hole H8	Shaft f7
0 - 0.12	0.3	+ 0.6	- 0.3
	1.3	- 0	- 0.7
0.12 - 0.24	0.4	+ 0.7	- 0.4
	1.6	- 0	- 0.9
0.24 - 0.40	0.5	+ 0.9	- 0.5
	2.0	- 0	- 1.1
<b>0.40 - 0.71</b>	<b>0.6</b>	<b>+ 1.0</b>	<b>- 0.6</b>
	<b>2.3</b>	<b>- 0</b>	<b>- 1.3</b>
0.71 - 1.19	0.8	+ 1.2	- 0.8
	2.8	- 0	- 1.6
1.19 - 1.97			
1.97 - 3.15			

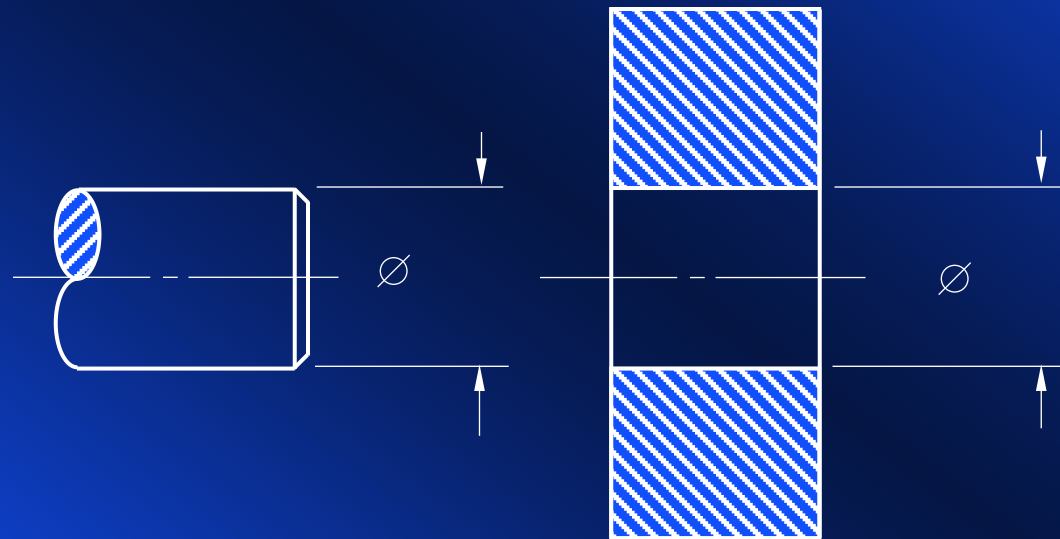

# Using the Standard Fit Tables to Assign Dimensions to Mating Parts

Notice that the *Hole* size, at its *lower* limit, reads “- 0”. Therefore, use the basic size (nominal 9/16 inch, converted to its decimal equivalent, .5625) as the lower limit for the dimension of the hole.

Nominal Size Range in Inches	Class RC 4		
	Limits of Clearance	Standard Limits	
		Hole H8	Shaft f7
0 - 0.12	0.3	+ 0.6	- 0.3
	1.3	- 0	- 0.7
0.12 - 0.24	0.4	+ 0.7	- 0.4
	1.6	- 0	- 0.9
0.24 - 0.40	0.5	+ 0.9	- 0.5
	2.0	- 0	- 1.1
0.40 - 0.71	0.6	+ 1.0	- 0.6
	2.3	- 0	- 1.3
0.71 - 1.19	0.8	+ 1.2	- 0.8
	2.8	- 0	- 1.6
1.19 - 1.97			
1.97 - 3.15			

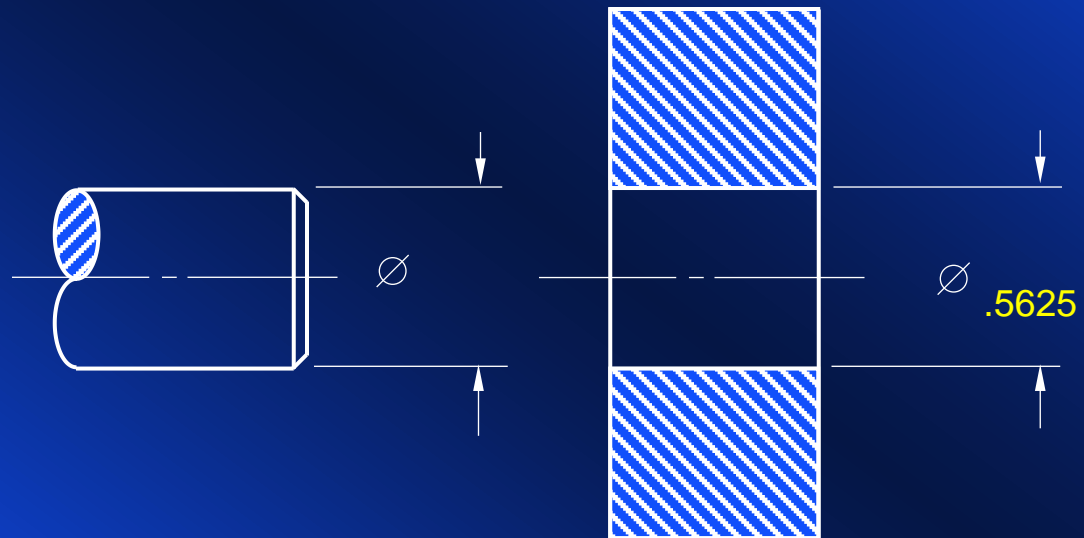

# Using the Standard Fit Tables to Assign Dimensions to Mating Parts

For the upper size limit for the hole you will notice that the value on the chart is +1.0. This value when converted into inches equals one thousandth of an inch — or ten ten-thousandths. Add the required .0010 to the basic size for the upper limit of the hole ( $.5625 + .0010 = .5635$ ). This is the upper size limit of the hole, which can now be added to the drawing. *It is added to the basic size value.*

Nominal Size Range in Inches	Class RC 4		
	Limits of Clearance	Standard Limits	
		Hole H8	Shaft f7
0 - 0.12	0.3	+ 0.6	- 0.3
	1.3	- 0	- 0.7
0.12 - 0.24	0.4	+ 0.7	- 0.4
	1.6	- 0	- 0.9
0.24 - 0.40	0.5	+ 0.9	- 0.5
	2.0	- 0	- 1.1
0.40 - 0.71	0.6	+ 1.0	- 0.6
	2.3	- 0	- 1.3
0.71 - 1.19	0.8	+ 1.2	- 0.8
	2.8	- 0	- 1.6
1.19 - 1.97			
1.97 - 3.15			

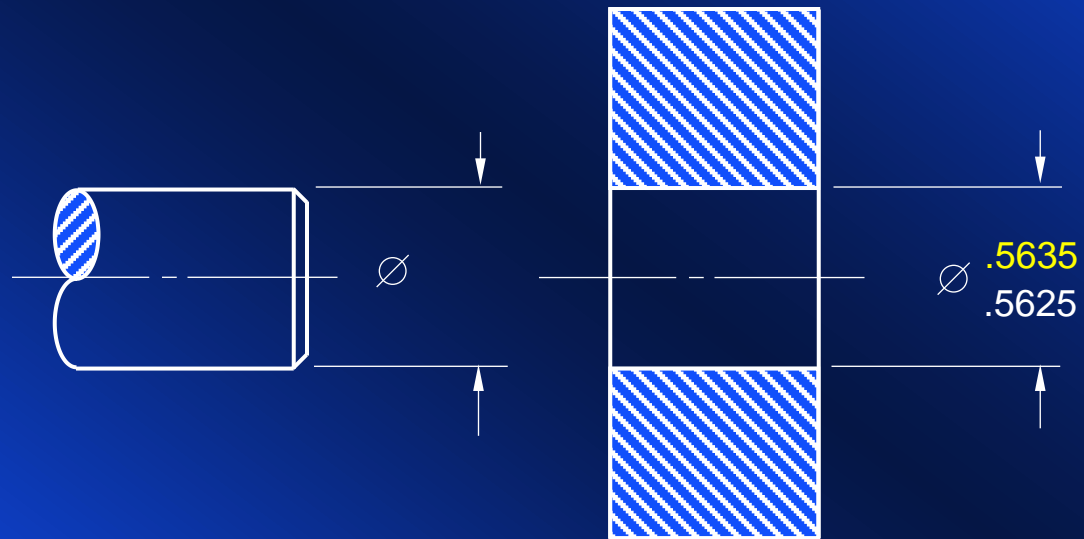

# Using the Standard Fit Tables to Assign Dimensions to Mating Parts

To determine the upper size limit of the shaft, we must subtract (note the sign in the table for the upper size limit of the shaft) 0.6 thousandths (or six ten-thousandths) from the basic size. The result will be .5619 ( $.5625 - .0006 = .5619$ ). Add this value to the drawing as the upper size limit on the shaft.

Nominal Size Range in Inches	Class RC 4		
	Limits of Clearance	Standard Limits	
		Hole H8	Shaft f7
0 - 0.12	0.3	+ 0.6	- 0.3
	1.3	- 0	- 0.7
0.12 - 0.24	0.4	+ 0.7	- 0.4
	1.6	- 0	- 0.9
0.24 - 0.40	0.5	+ 0.9	- 0.5
	2.0	- 0	- 1.1
0.40 - 0.71	0.6	+ 1.0	- 0.6
	2.3	- 0	- 1.3
0.71 - 1.19	0.8	+ 1.2	- 0.8
	2.8	- 0	- 1.6
1.19 - 1.97			
1.97 - 3.15			

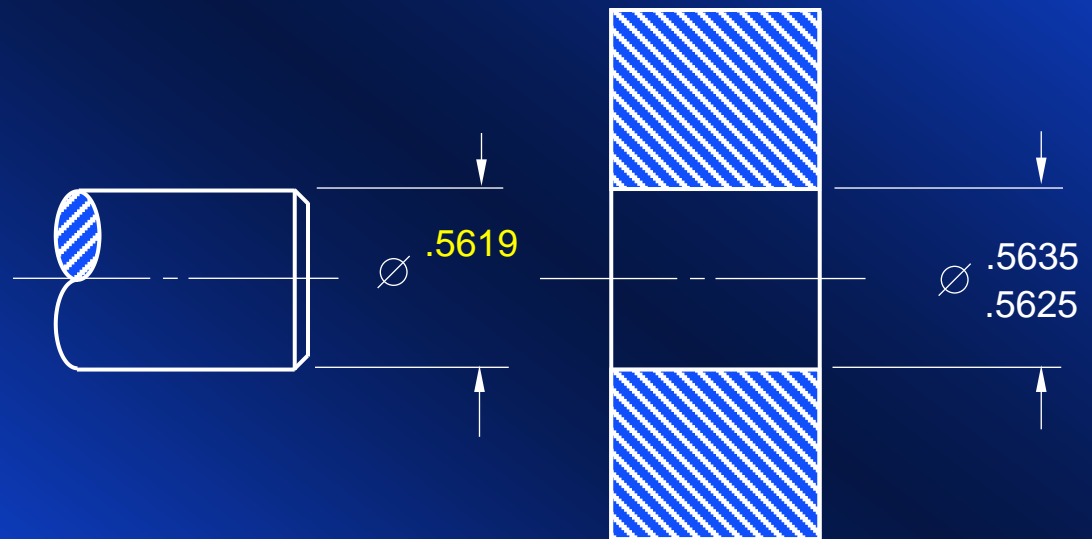

# Using the Standard Fit Tables to Assign Dimensions to Mating Parts

Finally, determine the lower limit of the shaft diameter by subtracting 1.3 thousandths (or thirteen ten-thousandths) from the *basic size*, and include the value in the drawing.

Nominal Size Range in Inches	Class RC 4		
	Limits of Clearance	Standard Limits	
		Hole H8	Shaft f7
0 - 0.12	0.3	+ 0.6	- 0.3
	1.3	- 0	- 0.7
0.12 - 0.24	0.4	+ 0.7	- 0.4
	1.6	- 0	- 0.9
0.24 - 0.40	0.5	+ 0.9	- 0.5
	2.0	- 0	- 1.1
0.40 - 0.71	0.6	+ 1.0	- 0.6
	2.3	- 0	- 1.3
0.71 - 1.19	0.8	+ 1.2	- 0.8
	2.8	- 0	- 1.6
1.19 - 1.97			
1.97 - 3.15			

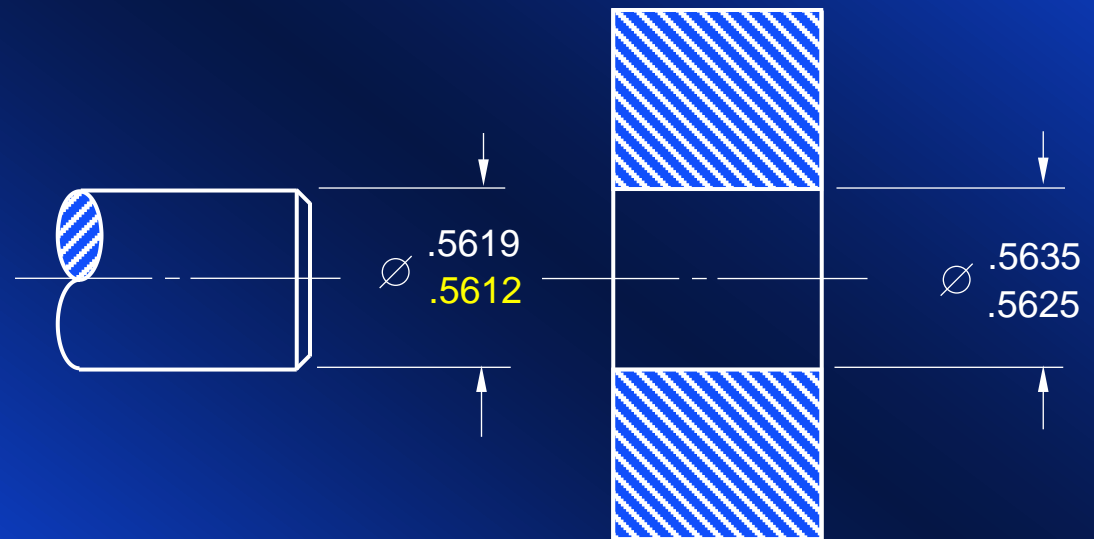



# Using the Standard Fit Tables to Assign Dimensions to Mating Parts

Now, look back to the column labeled “Limits of Clearance”. These values reveal the total amount of variation that can be allowed on a 9/16” RC 4 fit--when the parts are at maximum material condition and at least material condition.

On the *drawing*, compare the dimensions diagonally.

Nominal Size Range in Inches	Class RC 4		
	Limits of Clearance	Standard Limits	
		Hole H8	Shaft f7
0 - 0.12	0.3	+ 0.6	- 0.3
	1.3	- 0	- 0.7
0.12 - 0.24	0.4	+ 0.7	- 0.4
	1.6	- 0	- 0.9
0.24 - 0.40	0.5	+ 0.9	- 0.5
	2.0	- 0	- 1.1
<b>0.40 - 0.71</b>	<b>0.6</b>	<b>+ 1.0</b>	<b>- 0.6</b>
	<b>2.3</b>	<b>- 0</b>	<b>- 1.3</b>
0.71 - 1.19	0.8	+ 1.2	- 0.8
	2.8	- 0	- 1.6
1.19 - 1.97			
1.97 - 3.15			

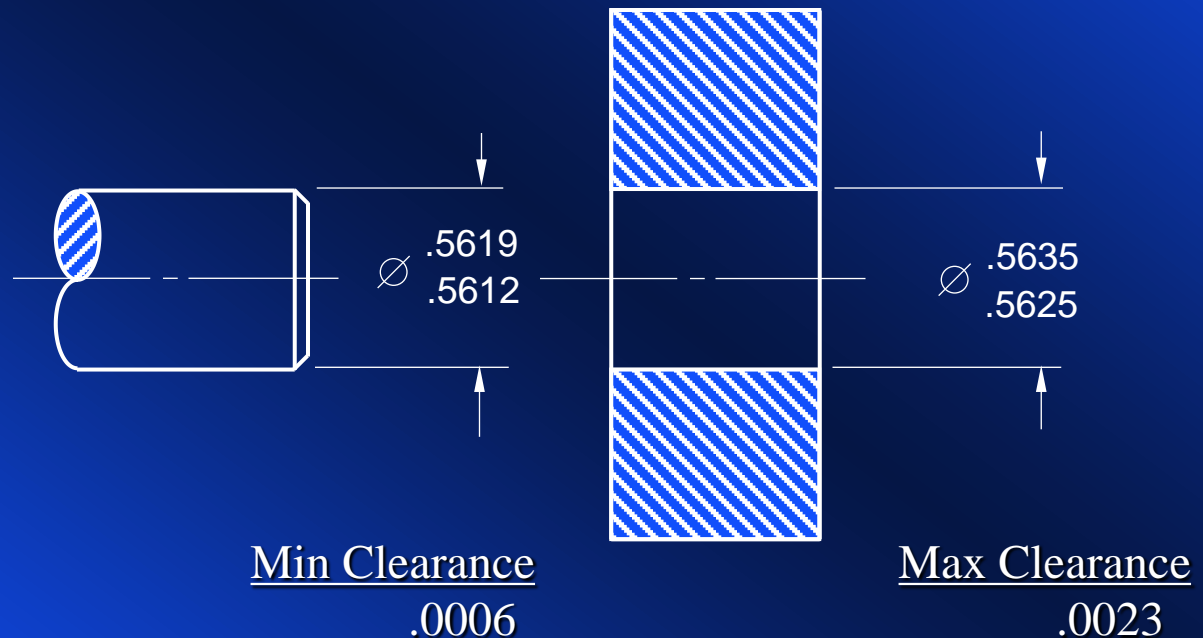

# Using the Standard Fit Tables to Assign Dimensions to Mating Parts

At maximum material condition (MMC — largest shaft; smallest hole), the difference is .0006, or 0.6 thousandths.

Nominal Size Range in Inches	Class RC 4		
	Limits of Clearance	Standard Limits	
		Hole H8	Shaft f7
0 - 0.12	0.3	+ 0.6	- 0.3
	1.3	- 0	- 0.7
0.12 - 0.24	0.4	+ 0.7	- 0.4
	1.6	- 0	- 0.9
0.24 - 0.40	0.5	+ 0.9	- 0.5
	2.0	- 0	- 1.1
0.40 - 0.71	0.6	+ 1.0	- 0.6
	2.3	- 0	- 1.3
0.71 - 1.19	0.8	+ 1.2	- 0.8
	2.8	- 0	- 1.6
1.19 - 1.97			
1.97 - 3.15			

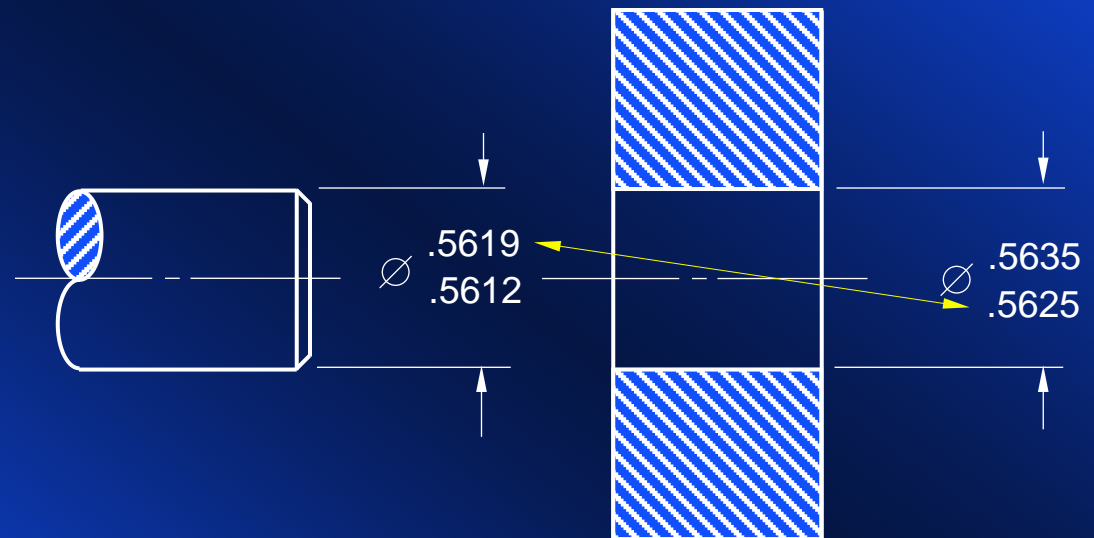

# Using the Standard Fit Tables to Assign Dimensions to Mating Parts

At least material condition (LMC — smallest shaft; largest hole), there is a clearance of .0023, or 2.3 thousandths.

Nominal Size Range in Inches	Class RC 4		
	Limits of Clearance	Standard Limits	
		Hole H8	Shaft f7
0 - 0.12	0.3	+ 0.6	- 0.3
	1.3	- 0	- 0.7
0.12 - 0.24	0.4	+ 0.7	- 0.4
	1.6	- 0	- 0.9
0.24 - 0.40	0.5	+ 0.9	- 0.5
	2.0	- 0	- 1.1
0.40 - 0.71	0.6	+ 1.0	- 0.6
	2.3	- 0	- 1.3
0.71 - 1.19	0.8	+ 1.2	- 0.8
	2.8	- 0	- 1.6
1.19 - 1.97			
1.97 - 3.15			

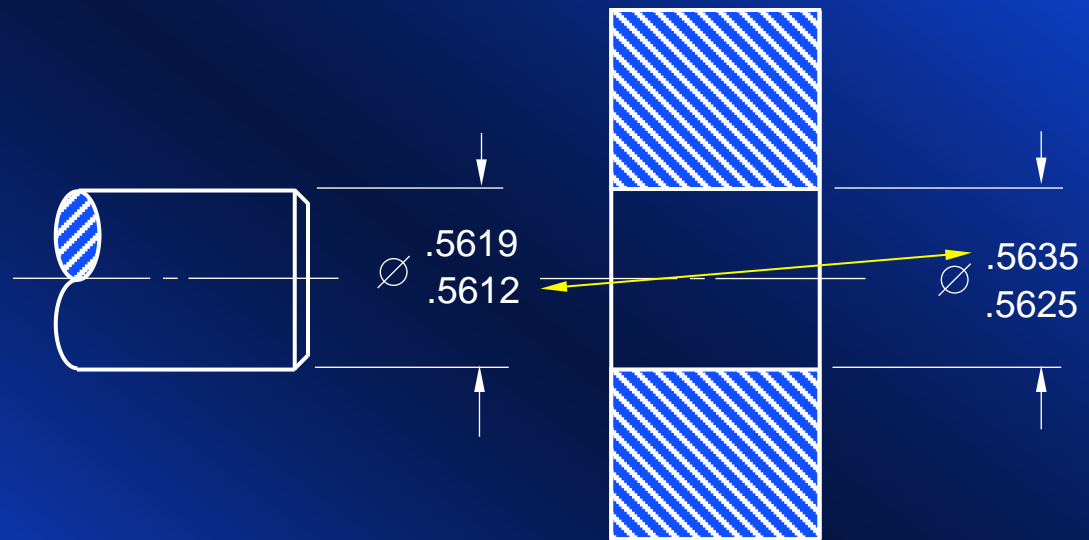

Values Referenced to Basic Size:  $\varnothing .5625 \begin{matrix} -.0006 \\ -.0013 \end{matrix}$        $\varnothing .5625 \begin{matrix} +.0010 \\ -.0000 \end{matrix}$

# Web Sites for Fits and Tolerances

<http://www.cobanengineering.com/Tolerances/ANSILimitsAndFits.asp> (very good)

[http://www.mech.uq.edu.au/courses/mech2110/standard\\_fits/index.html](http://www.mech.uq.edu.au/courses/mech2110/standard_fits/index.html)