

# Chapter 4

## Loading and Hauling

### *Part 2*

# 4-2 DOZERS

- **This section includes:**
  - **Tractors and Dozers**
  - **Dozer Blades**
  - **Estimating Dozer Production**
  - **Job Management**



# Tractors and Dozers

- A tractor equipped with a front-mounted earthmoving blade is known as a *dozer* or *bulldozer*.
- A dozer moves earth:
  - by lowering the blade and cutting until a full blade load of material is obtained.
  - It then pushes the material across the ground surface to the required location.

# Tractors and Dozers

- Both rubber-tired (or wheel) dozers and crawler (or track) dozers are available.
- crawler (or track) dozers
  - Because of their excellent traction and low ground pressure (typically 6 to 9 lb/sq in.; 0.4 to 0.6 bar), crawler dozers (Figure 4-6) are well suited for use in rough terrain or areas of low trafficability.
  - Low-ground-pressure models with extra-wide tracks are available having ground pressures as low as 3 lb/sq in. (0.2 bar).

- Crawler dozers can operate on steeper side slopes and climb greater grades than can wheel dozers.
- Wheel dozers can operate at higher speed than do crawler dozers.
- Wheel dozers are also capable of operating on paved roads without damaging the surface.
  - Crawler dozers cause damage.
- While the wheel tractor's dozing ability is limited somewhat by its lower traction and high ground pressure (25 to 35 lb/sq in.; 1.7 to 2.4 bars), its high ground pressure makes it an effective soil compactor.

# Tractors and Dozers

- Either rubber-tired or crawler tractors may be equipped with attachments other than dozer blades.
- These include rakes used for gathering up brush and small fallen trees, and plows, rippers, and scarifiers, which are used to break up hard surfaces.
- Tractors are also used to tow many items of construction equipment, such as:
  - compactors,
  - scrapers, and
  - wagons.





- Dozers may be equipped with:
  - direct-drive,
  - power-shift, or
  - hydrostatic transmissions.
- *Hydrostatic transmissions* utilize individual hydraulic motors to drive each track. Therefore,
  - the speed of each track may be infinitely varied, forward or reverse.
  - it is possible for a dozer equipped with a hydrostatic drive to turn in its own length by moving one track forward while the other track moves in reverse.

# Dozer Blades

- There are a number of types of dozer blades available, and the four most common types are illustrated in Figure 4-7.

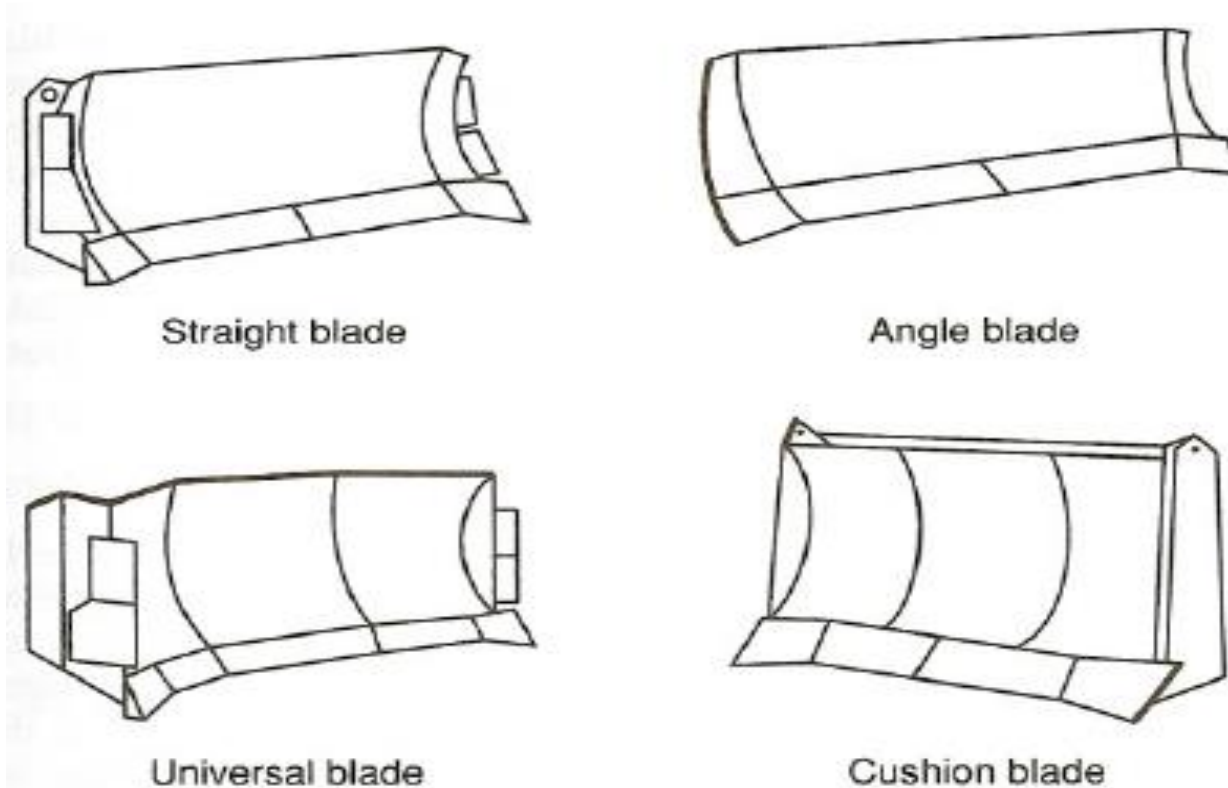

Figure 4-7: Common types of dozer blades



# Dozer Blades Adjustments

The three types of adjustments that maybe made to dozer blades are illustrated in Figure 4-8.

- **Tilting** the blade is useful for ditching and breaking up frozen or crusty soils.
- **Pitching** the blade forward reduces blade penetration and causes the loosened material to roll in front of the blade, whereas pitching the blade backward increases penetration.



**FIGURE 4-8:** Dozer blade adjustments.



# Dozer Blades

- **Angling** the blade is helpful in 3 purposes:
  - side-hill cutting,
  - ditching, and
  - moving material laterally.
- All the blades shown in Figure 4-7 may be tilted except the cushion blade.
- However, only the angle blade may be angled.

# Dozer Blades

- The wings on the universal blade (Figure 4-7) enable it to push a large volume of material over long distances.
  - However, its low horsepower per foot of cutting edge and per cubic yard limit its ability to penetrate hard soils or to move heavy materials.
- The straight blade is considered the most versatile dozer blade.
  - Its smaller size gives it good penetrating and load pushing ability.

# Dozer Blades

- Angle Blades

- Have the ability of angle blades to angle approximately  $25^\circ$  to either side makes them very effective in:
  - side hill cutting,
  - ditching, and
  - backfilling.
- They may also be used for rough grading and for moving material laterally.



# Dozer Blades

- The cushion blade :
  - is reinforced and equipped with shock absorbers to enable it to push-load scrapers.
  - It may also be used for cleanup of the loading or dumping areas and for general dozing when not push-loading scrapers.

# Dozer Blades

- Other available types of dozer blades include:
  - light-material U-blades,
  - special clearing blades, and
  - rip dozer blades (blades equipped with ripper shanks on each end).

# Dozer Blades

- The two indicators of potential dozer performance are based on the ratio of tractor power to blade size.
- These indicators are :
  - 1. horsepower per foot of cutting edge: provides a measure of the blade's ability to penetrate hard soils and
  - 2. horsepower per loose cubic yard rating: provides an indication of the blade's ability to push material once the blade is loaded..

# Estimating Dozer Production

- The basic earthmoving production equation (Equation 2-1) may be applied in estimating dozer production.
  - This method requires an estimate of the average blade load and the dozer cycle time.
- There are several methods available for estimating average blade load, including:
  - the blade manufacturer's capacity rating,
  - previous experience under similar conditions, and
  - actual measurement of several typical loads.

# Estimating Dozer Production

- A suggested method for calculating blade volume by measuring blade load is as follows:
  - Doze a full blade load, then lift the blade while moving forward on a
  - level surface until an even pile is formed.
  - Measure the width of the pile ( $W$ ) perpendicular to the blade and in line with the inside of each track or wheel. Average the two measurements.

# Estimating Dozer Production

- Measure the height ( $H$ ) of the pile in a similar manner.
- Measure the length of the pile parallel to the blade.
- Calculate blade volume using Equation 4-10.
  - Blade load (LCY) =  $0.0139 \times H(\text{ft}) \times W(\text{ft}) \times L(\text{ft})$
  - Blade load (LCM) =  $0.375 \times H(\text{m}) \times W(\text{m}) \times L(\text{m})$

# Estimating Dozer Production

- Total dozer cycle time is the sum of its:
  - fixed cycle time and
  - variable cycle time.
- Fixed cycle time (Table 4-4 ) represents the time required to:
  - maneuver, change gears, start loading, and dump.

**Table 4-4** Typical dozer fixed cycle times

<b>Operating Conditions</b>	<b>Time (min)</b>
Power-shift transmission	0.05
Direct-drive transmission	0.10
Hard digging	0.15

# Estimating Dozer Production

- Variable cycle time is the time required to doze and return (Table 4-5 ).
  - Since the haul distance is relatively short, a dozer usually returns in reverse gear.
  - Some manufacturers provide dozer production estimating charts for their equipment.



**Table 4-5** Typical dozer operating speeds

Operating Conditions	Speeds
Dozing	
Hard materials, haul 100 ft (30 m) or less	1.5 mi/h (2.4 km/h)
Hard materials, haul over 100 ft (30 m)	2.0 mi/h (3.2 km/h)
Loose materials, haul 100 ft (30 m) or less	2.0 mi/h (3.2 km/h)
Loose materials, haul over 100 ft (30 m)	2.5 mi/h (4.0 km/h)
Return	
100 ft (30 m) or less	Maximum reverse speed in second range (power shift) or reverse speed in gear used for dozing (direct drive)
Over 100 ft (30 m)	Maximum reverse speed in third range (power shift) or highest reverse speed (direct drive)

# EXAMPLE 4-6

- Estimate the production of the dozer that has the following information:
  - A power-shift crawler tractor has a rated blade capacity of **7.65 LCM**.
  - The dozer is excavating loose common earth and pushing it a distance of **61 m**.
  - Maximum reverse speed in third range is **8 km/h**.
  - job efficiency is 50 min/h.

# EXAMPLE 4-6

## Solution

Fixed time = 0.05 min (Table 4-4)

Dozing speed = 4.0 km/h (Table 4-5)

Dozing time =  $61 / (4 \times 16.7) = 0.91$  min

Note: 1 km/h = 16.7 m/min.

Return time =  $61 / (8 \times 16.7) = 0.45$  min

Cycle time =  $0.05 + 0.91 + 0.45 = 1.41$  min

Production =  $7.65 \times 50 / 60 \times 60 / 1.41 = 271$  LCM/h

# Job Management

- Some techniques used to increase dozer production include:
  - downhill dozing,
  - slot dozing, and
  - blade-to-blade dozing.
- By taking advantage of the force of gravity, downhill dozing enables blade load to be increased or cycle time to be reduced compared to dozing on the level.

# Job Management

- Slot dozing utilizes a shallow trench (or slot) cut between the loading and dumping areas to increase the blade capacity that can be carried on each cycle.
  - Under favorable conditions, slot dozing may increase dozer production as much as **50%**.

# Job Management

- Blade-to-blade dozing involves two dozers operating together with their blades almost touching.
  - This technique results in a combined blade capacity considerably greater than that of two single blades.
  - However, the technique is not efficient for use over short dozing distances because of the extra maneuvering time required.
- Mechanically coupled side by-side ( $S \times S$ ) dozers equipped with a single large blade are available and are more productive than are blade-to-blade dozers.

## 4-3 LOADERS

- A tractor equipped with a front-end bucket is called a *loader*, *front-end loader*, or *bucket loader*.
- Both wheel loaders (Figure 4-9) and track loaders (Figure 4-10) are available.



**FIGURE4-9:** Articulated wheel loader with articulated hauler. (Courtesy of Volvo Construction Equipment North America, Inc.)





## **FIGURE4-10: Track loader.**

(Courtesy of John Deere Construction & Forestry Company)



- Loaders are used for:
  - excavating soft to medium-hard material,
  - loading hoppers and haul units,
  - stockpiling material,
  - backfilling ditches, and
  - moving concrete and other construction materials.

- Wheel loaders:
  - possess excellent job mobility and are capable of over-the road movement between jobs at speeds of 25 mi/h or higher.
  - While their ground pressure is relatively low and may be varied by the use of different size tires and by changing inflation pressures, they do not have the all-terrain capability of track loaders.
  - Most modern wheel loaders are *articulated*.
    - That is, they are hinged between the front and rear axles to provide greater maneuverability.





- Track loaders :
  - are capable of overcoming steeper grades and side slopes than are wheel loaders.
  - Their low ground pressure and high tractive effort enable them to operate in all but the lowest trafficability soils.
  - Because of their lower speed, their production is less than that of a wheel loader over longer haul distances.

# Estimating Loader Production

- Loader production may be estimated as the product of average bucket load multiplied by cycles per hour (Equation 2-1).
- **Basic cycle time** for a loader, wheel or track loader, (Table 4-6) includes the time required for **loading, dumping, making four reversals of direction**, and traveling a minimum distance (15 ft or less for track loaders).

making four reversals of direction

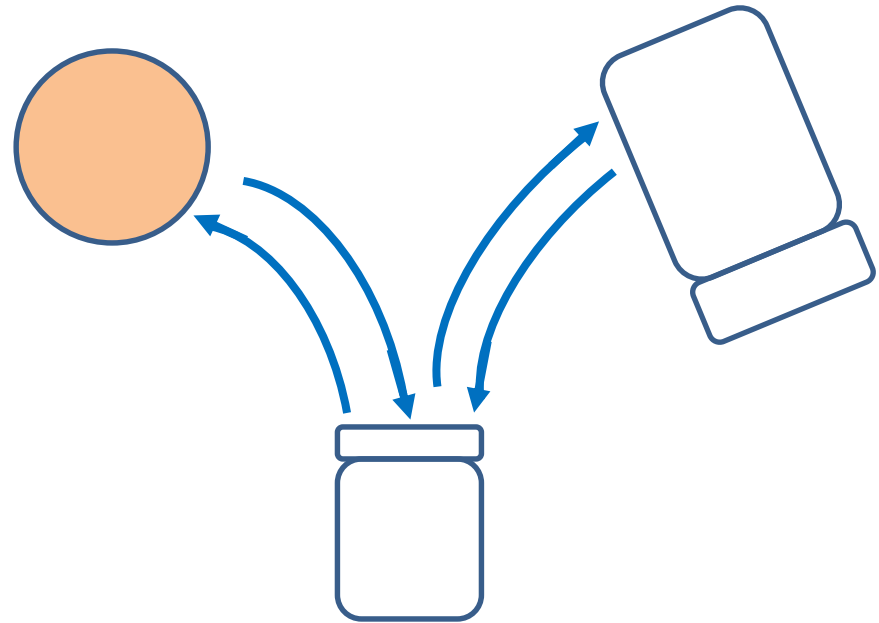

**TABLE 4-6:** Basic loader cycle time

Loading Conditions	Basic Cycle Time (min)	
	Articulated Wheel Loader	Track Loader
Loose materials	0.35	0.30
Average material	0.50	0.35
Hard materials	0.65	0.45

**FIGURE 4-15:** Travel time, wheel loader (*haul + return*).

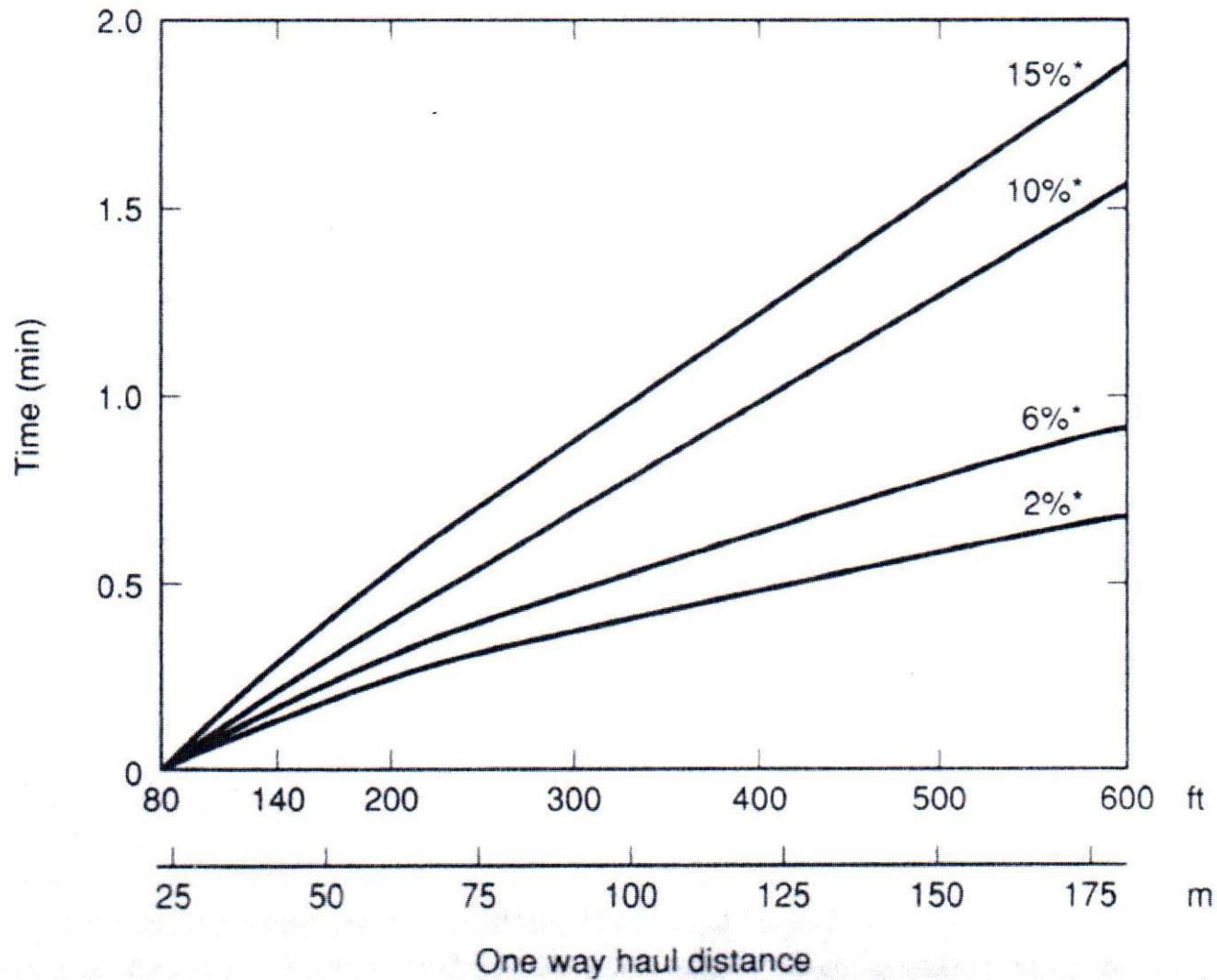

\*Effective grade



# Estimating Loader Production

- Federal Highway Administration (FHWA) studies have shown little variation in basic cycle time for wheel loaders up to a distance of 80 ft (25 m) between loading and dumping position.
  - Therefore, travel time should not be added until one-way distance exceeds this distance.
- Loader bucket capacity is rated in heaped (loose) volume, as shown in Table 3-1.
  - Bucket capacity should be adjusted by a bucket fill factor (Table 3-2) to obtain the best estimate of actual bucket volume.

# EXAMPLE 4-7

- Estimate the hourly production in loose volume (LCM) of :
  - a 2.68-m<sup>3</sup> wheel loader excavating sand and gravel (average material) from a pit and moving it to a stockpile.
  - The average haul distance is 61 m,
  - the effective grade is 6%,
  - the bucket fill factor is 1.00, and
  - job efficiency is 50 min/h.

# EXAMPLE 4-7

- **Solution**

Bucket volume =  $2.68 \times 1 = 2.68$  LCM

Basic cycle time = 0.50 min (Table 4-6)

Travel time = 0.30 min (Figure 4-14)

Cycle time =  $0.50 + 0.30 = 0.80$  min

Production =  $2.68 \times 50/60 \times 60/0.80 = 168$  LCM/h

---

Loading Conditions	Basic Cycle Time (min)	
	Articulated Wheel Loader	Track Loader
Loose materials	0.35	0.30
Average material	0.50	0.35
Hard materials	0.65	0.45

---

# Job Management

- Cutting of tires is a major problem when loading shot rock with a wheel loader.
- Type L-5 tires (rock, extra deep tread) should be used to increase tire life when loading rock.

# Job Management

- In selection of a loader, consideration must also be given to the following:
  - (1) the weight of the material being handled may limit the size of the bucket that may be used on a loader.
    - Because of tipping load limitations,
  - (2) clearances required during loading and dumping.
  - (3) optimum positioning of the loader and haul units
    - to minimize loading, maneuver, and dump times.

# Job Management

- Multisegment buckets, also called 4-in-1 buckets and multipurpose buckets (Figure 4-16), are capable of performing as a clamshell, dozer, or scraper, as well as a conventional loader.
  - Such buckets are often more effective than are conventional buckets in handling wet, sticky materials.
- Blasting or ripping hard materials before attempting to load them will often increase loader production in such materials.

**Figure 4-16:**  
Multisegment loader bucket.

