

13. Buckling of Columns

*13.6 DESIGN OF COLUMNS FOR CONCENTRIC LOADING

- To account for behavior of different-length columns, design codes specify several formulae that will best fit the data within the short, intermediate, and long column range.

Steel columns

- Structural steel columns are designed on the basis of formulae proposed by the Structural Stability Research Council (SSRC).
- Factors of safety are applied to the formulae and adopted as specs for building construction by the American Institute of Steel Construction (AISC).

13. Buckling of Columns

*13.6 DESIGN OF COLUMNS FOR CONCENTRIC LOADING

Steel columns

- For long columns, the Euler formula is used. A factor of safety F.S. = $23/12 \approx 1.92$ is applied. Thus for design,

$$\sigma_{allow} = \frac{12\pi^2 E}{23(KL/r)^2} \quad \left(\frac{KL}{r}\right)_c \leq \frac{KL}{r} \leq 200 \quad (13 - 21)$$

- Value of slenderness ratio obtained by

$$\left(\frac{KL}{r}\right)_c = \sqrt{\frac{2\pi^2 E}{\sigma_Y}} \quad (13 - 22)$$

13. Buckling of Columns

*13.6 DESIGN OF COLUMNS FOR CONCENTRIC LOADING

Steel columns

- For slenderness ratio lesser than $(KL/r)_c$, the design eqn is

$$\sigma_{allow} = \frac{\left[1 - \frac{(KL/r)^2}{2(KL/r)_c^2} \right] \sigma_Y}{\left\{ \left(\frac{5}{3} \right) + \left[\frac{3 \left(\frac{KL}{r} \right)}{8 \left(\frac{KL}{r} \right)_c} \right] - \left[\frac{\left(\frac{KL}{r} \right)^3}{8 \left(\frac{KL}{r} \right)_c^3} \right] \right\}} \quad (13 - 23)$$

13. Buckling of Columns

*13.6 DESIGN OF COLUMNS FOR CONCENTRIC LOADING

Steel columns

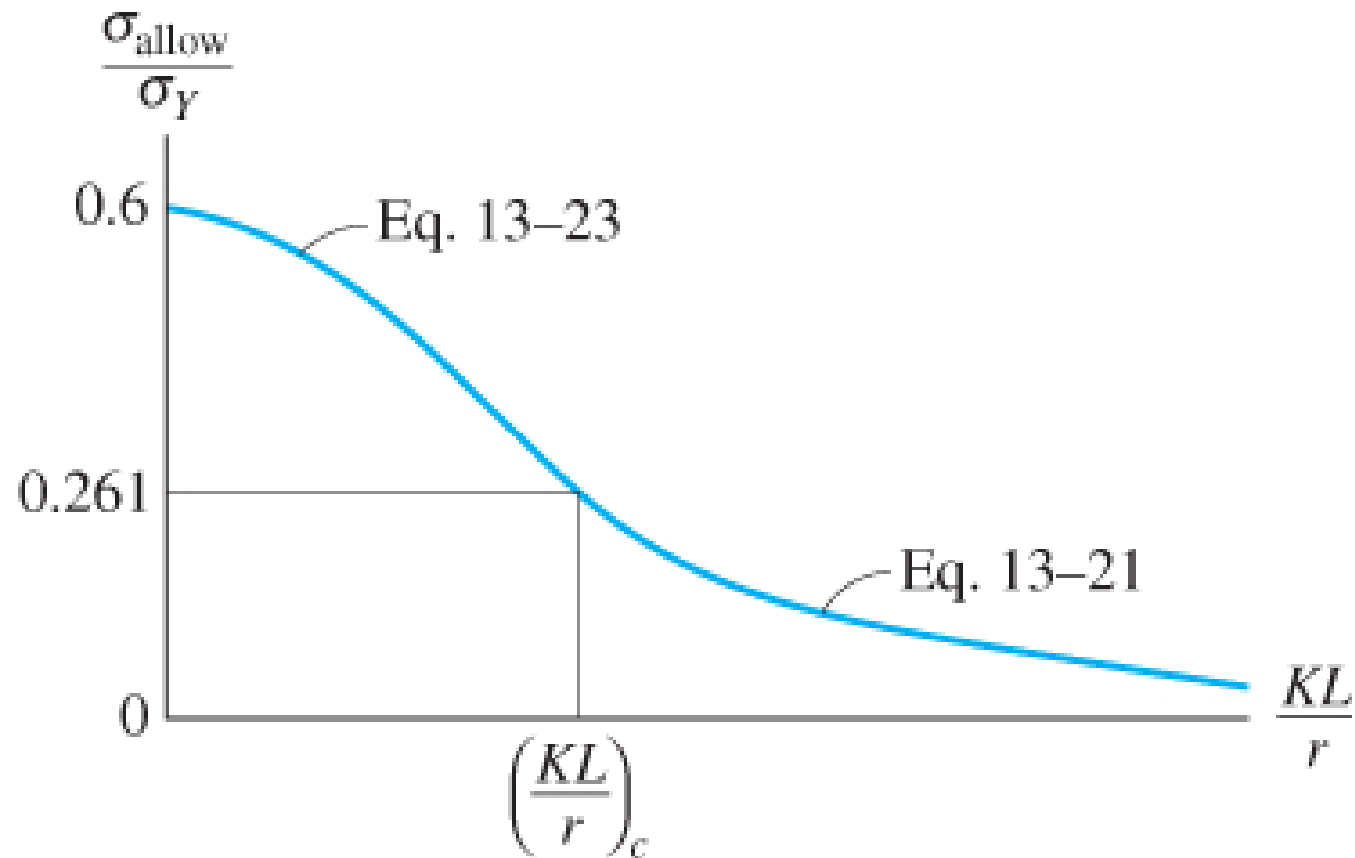

13. Buckling of Columns

*13.6 DESIGN OF COLUMNS FOR CONCENTRIC LOADING

Aluminum columns

- Design equations are specified by the Aluminum Association, applicable for specific range of slenderness ratios.
- For a common alloy (2014-T6), we have

$$\sigma_{allow} = 195 \text{ MPa} \qquad 0 \leq \frac{KL}{r} \leq 12 \qquad (13 - 24)$$

$$\sigma_{allow} = \left[214.5 - 1.628 \left(\frac{KL}{r} \right) \right] \text{ MPa} \qquad 12 < \frac{KL}{r} < 55 \qquad (13 - 25)$$

$$\sigma_{allow} = \frac{378125 \text{ MPa}}{(KL/r)^2} \qquad 55 \leq \frac{KL}{r} \qquad (13 - 26)$$

13. Buckling of Columns

*13.6 DESIGN OF COLUMNS FOR CONCENTRIC LOADING

Aluminum columns

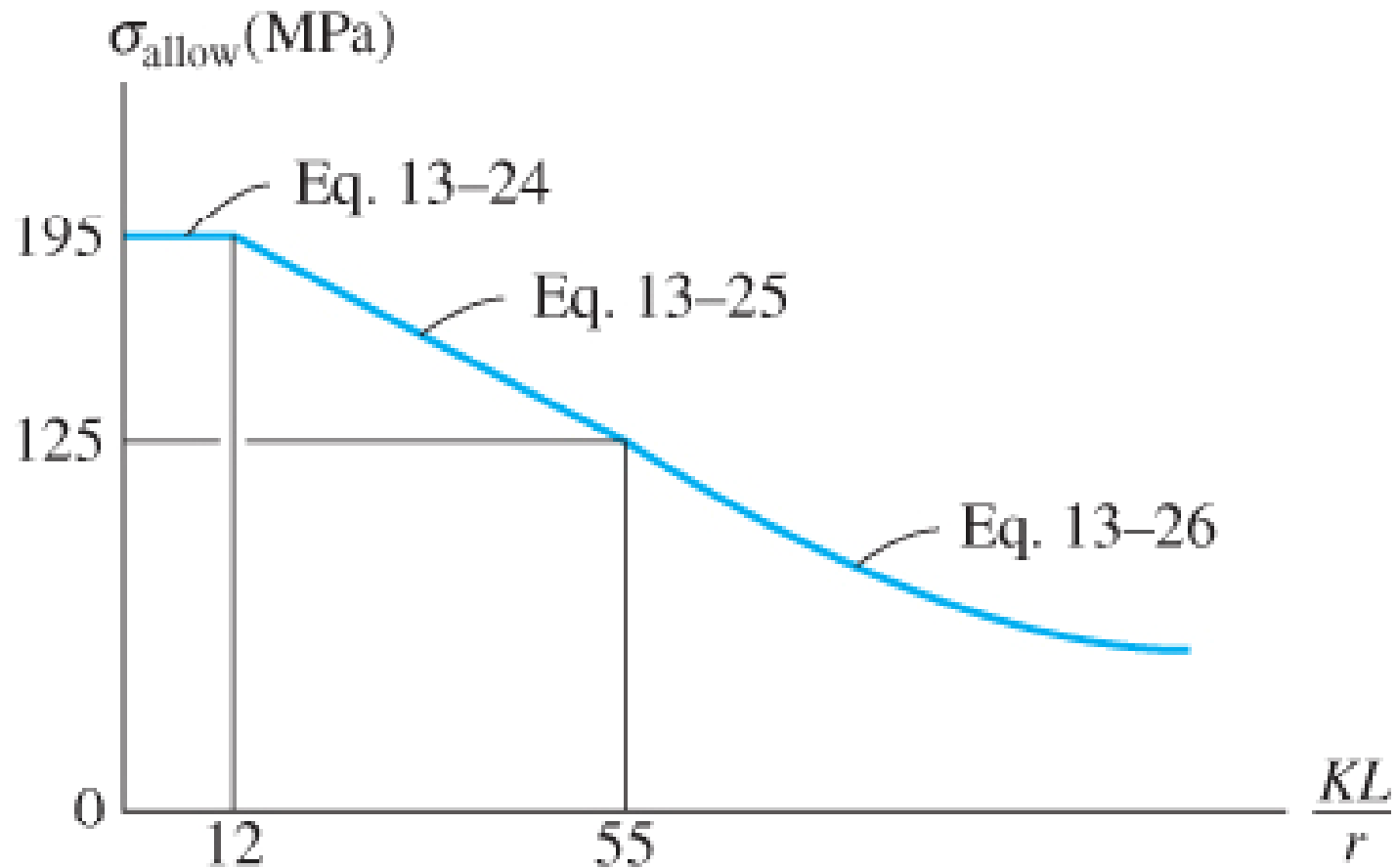

13. Buckling of Columns

*13.6 DESIGN OF COLUMNS FOR CONCENTRIC LOADING

Timber columns

- Timber design formulae published by the National Forest Products Association (NFPA) or American Institute of Timber Construction (AITC).

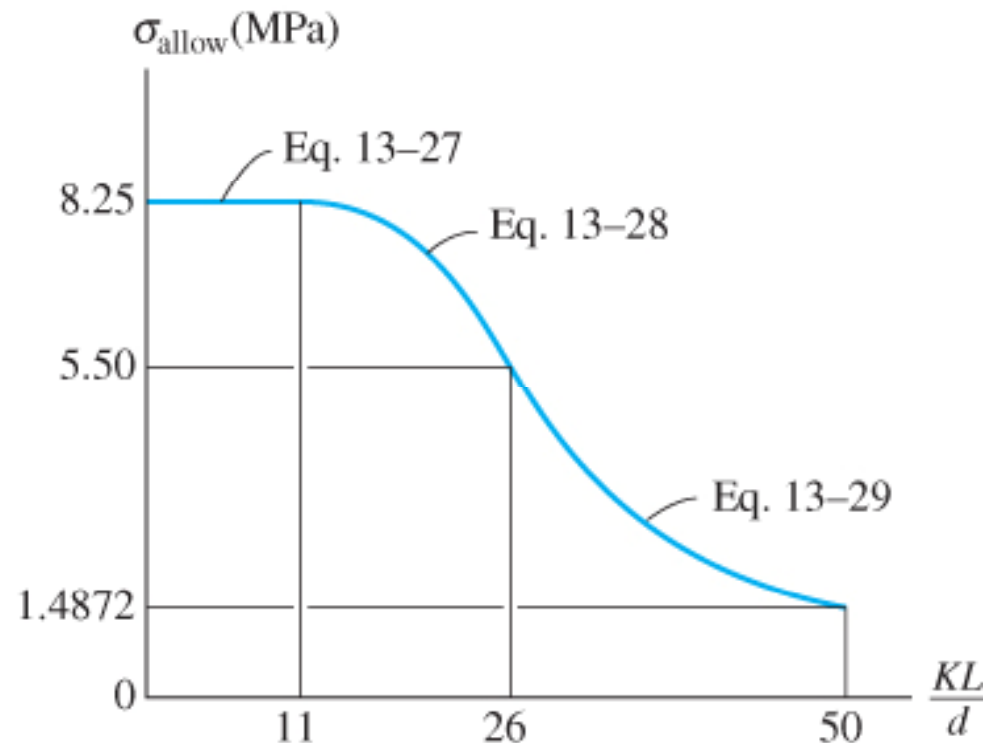

13. Buckling of Columns

*13.6 DESIGN OF COLUMNS FOR CONCENTRIC LOADING

Timber columns

- NFPA's formulae for short, intermediate and long columns having a rectangular x-section of dimensions b and d (smallest dimension),

$$\sigma_{allow} = 8.25 \text{ MPa} \qquad 0 \leq \frac{KL}{d} \leq 11 \qquad (13 - 27)$$

$$\sigma_{allow} = 8.25 \left[1 - \frac{1}{3} \left(\frac{KL/d}{26.0} \right)^2 \right] \text{ MPa} \qquad 11 < \frac{KL}{d} \leq 26 \qquad (13 - 28)$$

$$\sigma_{allow} = \frac{3718 \text{ MPa}}{(KL/d)^2} \qquad 26 < \frac{KL}{d} \leq 50 \qquad (13 - 29)$$

13. Buckling of Columns

*13.6 DESIGN OF COLUMNS FOR CONCENTRIC LOADING

Procedure for analysis

Column analysis

- When using any formula to analyze a column, or to find its allowable load, it is necessary to calculate the slenderness ratio in order to determine which column formula applies.
- Once the average allowable stress has been computed, the allowable load in the column is determined from $P = \sigma_{\text{allow}}A$.

13. Buckling of Columns

*13.6 DESIGN OF COLUMNS FOR CONCENTRIC LOADING

Procedure for analysis

Column design

- If a formula is used to design a column, or to determine the column's x-sectional area for a given loading and effective length, then a trial-and-check procedure generally must be followed if the column has a composite shape, such as a wide-flange section.
- One way is to assume the column's x-sectional area, A' , and calculate the corresponding stress $\sigma' = P/A'$.

13. Buckling of Columns

*13.6 DESIGN OF COLUMNS FOR CONCENTRIC LOADING

Procedure for analysis

Column design

- Also, with A' use an appropriate design formula to determine the allowable stress σ_{allow} .
- From this, calculate the required column area
$$A_{req'd} = P/\sigma_{allow}$$
- If $A' > A_{req'd}$, the design is safe. When making comparison, it is practical to require A' to be close to but greater than $A_{req'd}$, usually within 2-3%. A redesign is necessary if $A' > A_{req'd}$.

13. Buckling of Columns

*13.6 DESIGN OF COLUMNS FOR CONCENTRIC LOADING

Procedure for analysis

Column design

- Whenever a trial-and-check procedure is repeated, the choice of an area is determined by the previously calculated required area.
- In engineering practice, this method for design is usually shortened through the use of computer software or published tables and graphs.

13. Buckling of Columns

EXAMPLE 13.6

An A-26 steel W250×149 member is used as a pin-supported column. Using AISC column design formulae, determine the largest load that it can safely support.

$$E_{st} = 200(10^3) \text{ MPa}, \quad \sigma_Y = 250 \text{ MPa}.$$

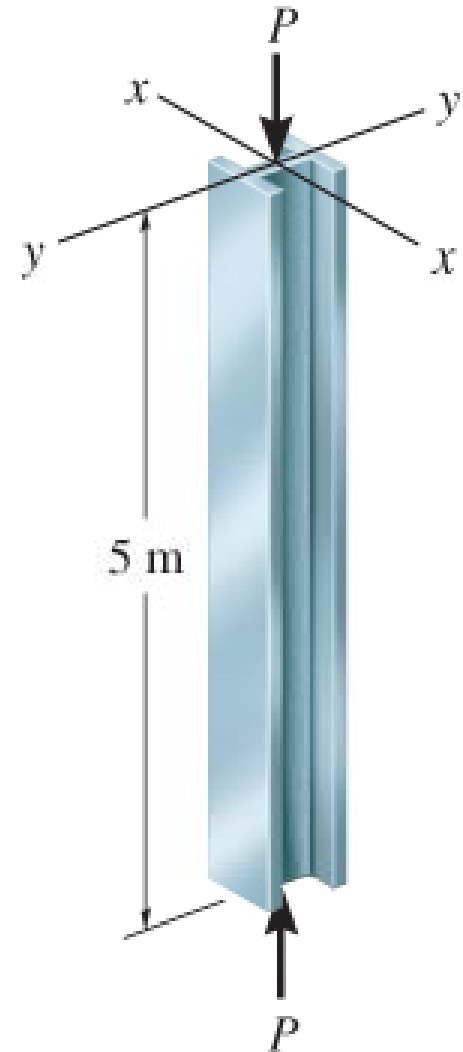

13. Buckling of Columns

EXAMPLE 13.6 (SOLN)

From Appendix B,

$$A = 19000 \text{ mm}^2; \quad r_x = 117 \text{ mm}; \quad r_y = 67.4 \text{ mm}.$$

Since $K = 1$ for both x and y axes buckling, slenderness ratio is largest if r_y is used. Thus

$$\frac{KL}{r} = \frac{1(5 \text{ m})(1000 \text{ mm/m})}{(67.4 \text{ mm})} = 74.18$$

From Eqn 13-22,

$$\begin{aligned} \left(\frac{KL}{r} \right)_c &= \sqrt{\frac{2\pi^2 E}{\sigma_Y}} \\ &= \sqrt{\frac{2\pi^2 (200)(10^3) \text{ MPa}}{250 \text{ MPa}}} = 125.66 \end{aligned}$$

13. Buckling of Columns

EXAMPLE 13.6 (SOLN)

Here $0 < KL/r < (KL/r)_c$, so Eqn 13-23 applies

$$\begin{aligned}\sigma_{allow} &= \frac{\left[1 - \frac{(74.18)^2}{2(125.66)^2} \right] 250 \text{ MPa}}{\left(\frac{5}{3} \right) + \left[\frac{3(74.18)}{8(125.66)} \right] - \left[\frac{(74.18)^3}{8(125.66)^3} \right]} \\ &= 110.85 \text{ MPa}\end{aligned}$$

Allowable load P on column is

$$\sigma_{allow} = \frac{P}{A}; \quad 110.85 \text{ N/mm}^2 = \frac{P}{19000 \text{ mm}^2}$$

$$P = 2106150 \text{ N} = 2106 \text{ kN}$$

13. Buckling of Columns

Example 13.7

The steel rod in Fig. 13–28 is to be used to support an axial load of 80 kN. If $E_s = 210(10^3)$ MPa and $\sigma_y = 360$ MPa, determine the smallest diameter of the rod as allowed by the AISC specification. The rod is fixed at both ends.

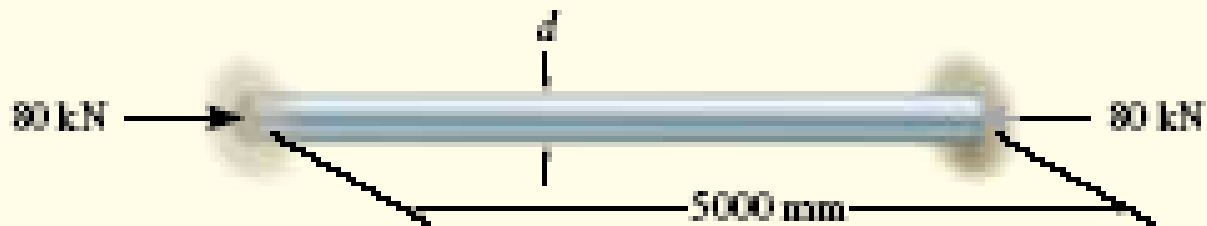

13. Buckling of Columns

Solution

For a circular cross section the radius of gyration becomes

$$r = \sqrt{\frac{I}{A}} = \sqrt{\frac{(1/4)\pi(d/2)^4}{(1/4)\pi d^2}} = \frac{d}{4}$$

Applying Eq. 13-22, we have

$$\left(\frac{KL}{r}\right)_c = \sqrt{\frac{2\pi^2 E}{\sigma_Y}} = \sqrt{\frac{2\pi^2 [210(10^3) \text{ MPa}]}{360 \text{ MPa}}} = 107.3$$

Since the rod's radius of gyration is unknown, KL/r is unknown, and therefore a choice must be made as to whether Eq. 13-21 or Eq. 13-23 applies. We will consider Eq. 13-21. For a fixed-end column $K = 0.5$, so

$$\begin{aligned}\sigma_{\text{allow}} &= \frac{12\pi^2 E}{23(KL/r)^2} \\ \frac{80(10^3) \text{ N}}{(1/4)\pi d^2} &= \frac{12\pi^2 [210(10^3) \text{ N/mm}^2]}{23[0.5(5000 \text{ mm})/(d/4)]^2} \\ \frac{101.86 \times 10^3}{d^2} &= 0.0108d^2 \text{ mm} \\ d &= 55.42 \text{ mm}\end{aligned}$$

Use

$$d = 56 \text{ mm} \quad \text{Ans.}$$

For this design, we must check the slenderness-ratio limits; i.e.,

$$\frac{KL}{r} = \frac{0.5(5)(1000)}{(56/4)} = 179$$

Since $107.3 < 179 < 200$, use of Eq. 13-21 is appropriate.

13. Buckling of Columns

EXAMPLE 13.8

A bar having a length of 750 mm is used to support an axial compressive load of 60 kN. It is pin-supported at its ends and made from a 2014-T6 aluminum alloy. Determine the dimensions of its x-sectional area if its width is to be twice its thickness.

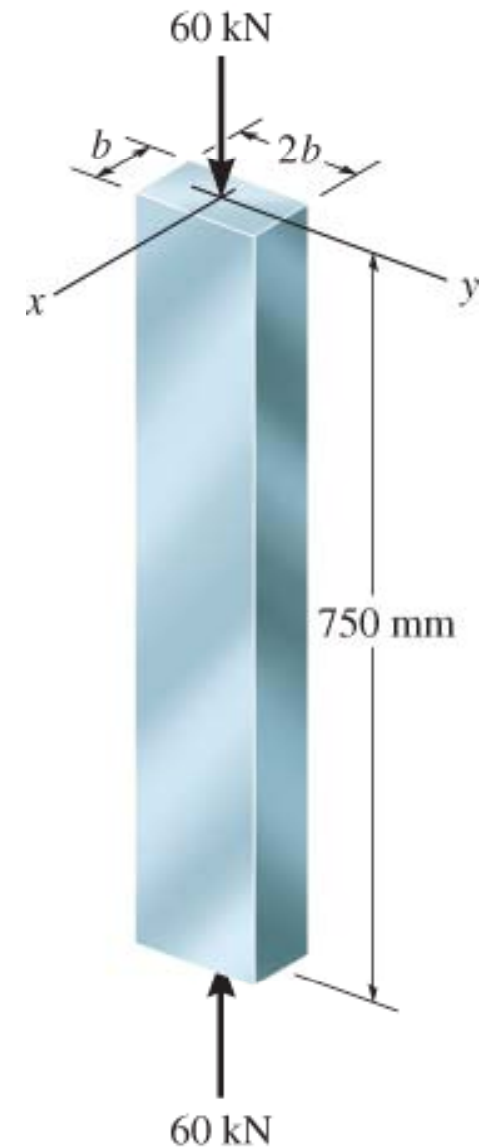

13. Buckling of Columns

EXAMPLE 13.8 (SOLN)

Since $KL = 750$ mm is the same for $x-x$ and $y-y$ axes buckling, largest slenderness ratio is determined using smallest radius of gyration, using $I_{\min} = I_y$:

$$\frac{KL}{r_y} = \frac{KL}{\sqrt{I_y/A}} = \frac{1(750)}{\sqrt{(1/12)2b(b^3)/[2b(b)]}} = \frac{2598.1}{b} \quad (1)$$

Since we do not know the slenderness ratio, we apply Eqn 13-24 first,

$$\frac{P}{A} = 195 \text{ N/mm}^2; \quad \frac{60(10^3) \text{ N}}{2b(b)} = 195 \text{ N/mm}^2$$

$$b = 12.40 \text{ mm}$$

13. Buckling of Columns

EXAMPLE 13.8 (SOLN)

Checking slenderness ratio,

$$\frac{KL}{r} = \frac{2598.1}{12.40} = 209.5 > 12$$

Try Eqn 13-26, which is valid for $KL/r \geq 55$;

$$\frac{P}{A} = \frac{378125 \text{ MPa}}{(KL/r)^2}$$

$$\frac{60(10^3)}{2b(b)} = \frac{378125}{(2598.1/b)^2}$$

$$b = 27.05 \text{ mm}$$

13. Buckling of Columns

EXAMPLE 13.8 (SOLN)

From Eqn (1),

$$\frac{KL}{r} = \frac{2598.1}{27.05} = 96.00 > 55 \quad \text{OK!}$$

Note: It would be satisfactory to choose the x-section with dimensions 27 mm by 54 mm.

13. Buckling of Columns

EXAMPLE 13.9

A board having x-sectional dimensions of 150 mm by 40 mm is used to support an axial load of 20 kN.

If the board is assumed to be pin-supported at its top and base, determine its greatest allowable length L as specified by the NFPA.

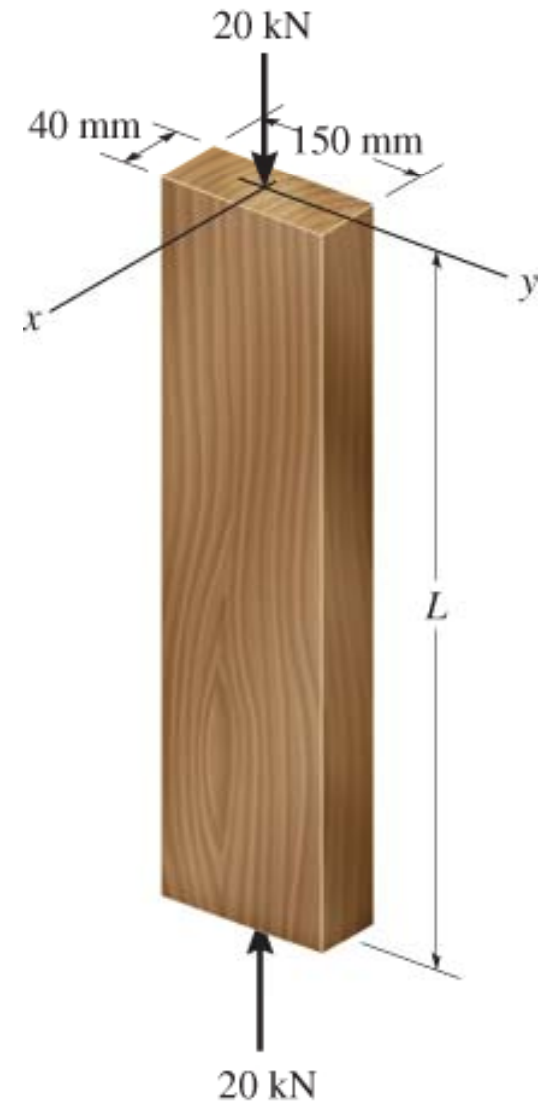

13. Buckling of Columns

EXAMPLE 13.9 (SOLN)

By inspection, board will buckle about the y axis. In the NFPA eqns, $d = 40$ mm.

Assuming that Eqn 13-29 applies, we have

$$\frac{P}{A} = \frac{3718 \text{ MPa}}{(KL/d)^2}$$
$$\frac{20(10^3) \text{ N}}{(150 \text{ mm})(40 \text{ mm})} = \frac{3718 \text{ N/mm}^2}{(1L/40 \text{ mm})^2}$$
$$L = 1336 \text{ mm}$$

13. Buckling of Columns

EXAMPLE 13.9 (SOLN)

Here
$$\frac{KL}{d} = \frac{(1)1336 \text{ mm}}{40 \text{ mm}} = 33.4$$

Since $26 < KL/d \leq 50$, the solution is valid.

13. Buckling of Columns

*13.7 DESIGN OF COLUMNS FOR ECCENTRIC LOADING

- A column may be required to support a load acting at its edge or on an angle bracket attached to its side.
- The bending moment $M = Pe$, caused by eccentric loading, must be accounted for when column is designed.

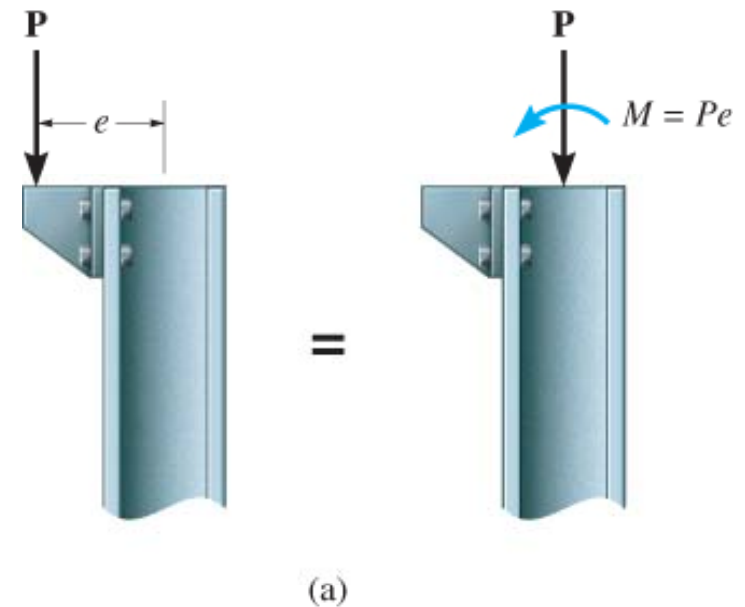

Use of available column formulae

- Stress distribution acting over x-sectional area of column shown is determined from both axial force P and bending moment $M = Pe$.

13. Buckling of Columns

*13.7 DESIGN OF COLUMNS FOR ECCENTRIC LOADING

Use of available column formulae

- Maximum compressive stress is

$$\sigma_{\max} = \frac{P}{A} + \frac{Mc}{I} \quad (13 - 30)$$

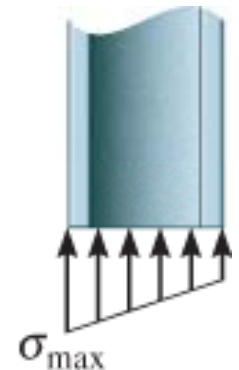

- A typical stress profile is also shown here. (b)
- If we assume entire x-section is subjected to uniform stress σ_{\max} , then we can compare it with σ_{allow} , which is determined from formulae given in chapter 13.6.
- If $\sigma_{\max} \leq \sigma_{\text{allow}}$, then column can carry the specified load.

13. Buckling of Columns

*13.7 DESIGN OF COLUMNS FOR ECCENTRIC LOADING

Use of available column formulae

- Otherwise, the column's area A is increased and a new σ_{\max} and σ_{allow} are calculated.
- This method of design is rather simple to apply and works well for columns that are short or intermediate length.
- Calculations of σ_{allow} is usually done using the largest slenderness ratio for the column regardless of the axis about the column experiences bending.

13. Buckling of Columns

*13.7 DESIGN OF COLUMNS FOR ECCENTRIC LOADING

Interaction formula

- It is sometimes desirable to see how the bending and axial loads interact when designing an eccentrically loaded column.
- We will consider the separate contributions made to the total column area from the axial force and the moment.
- If allowable stress for axial load is $(\sigma_a)_{allow}$, then required area for the column needed to support the load P is

$$A_a = \frac{P}{(\sigma_a)_{allow}}$$

13. Buckling of Columns

*13.7 DESIGN OF COLUMNS FOR ECCENTRIC LOADING

Interaction formula

- Similarly, if allowable bending stress is $(\sigma_b)_{allow}$, then since $I = Ar^2$, required area of column needed to resist eccentric moment is determined from flexure formula,

$$A_b = \frac{Mc}{(\sigma_b)_{allow} r^2}$$

13. Buckling of Columns

*13.7 DESIGN OF COLUMNS FOR ECCENTRIC LOADING

Interaction formula

- Thus, total area A for the column needed to resist both axial force and bending moment requires that

$$A_a + A_b = \frac{P}{(\sigma_a)_{allow}} + \frac{Mc}{(\sigma_b)_{allow} r^2} \leq A$$

$$\text{or} \quad \frac{P/A}{(\sigma_a)_{allow}} + \frac{Mc/Ar^2}{(\sigma_b)_{allow}} \leq 1$$

$$\frac{\sigma_a}{(\sigma_a)_{allow}} + \frac{\sigma_b}{(\sigma_b)_{allow}} \leq 1 \quad (13-31)$$

13. Buckling of Columns

*13.7 DESIGN OF COLUMNS FOR ECCENTRIC LOADING

Interaction formula

σ_a = axial stress caused by force P and determined from $\sigma_a = P/A$, where A is the x-sectional area of the column.

σ_b = bending stress caused by an eccentric load or applied moment M ; σ_b is found from $\sigma_b = Mc/I$, where I is the moment of inertia of x-sectional area computed about the bending or neutral axis.

$$\frac{\sigma_a}{(\sigma_a)_{allow}} + \frac{\sigma_b}{(\sigma_b)_{allow}} \leq 1$$
$$\frac{P}{(\sigma_a)_{allow}} + \frac{Mc}{(\sigma_b)_{allow} r^2} \leq A \quad (13-31)$$

13. Buckling of Columns

*13.7 DESIGN OF COLUMNS FOR ECCENTRIC LOADING

Interaction formula

$(\sigma_a)_{allow}$ = allowable axial stress as defined by formulae given in chapter 13.6 or by design code specs. Use the largest slenderness ratio for the column, regardless of which axis it experiences bending.

$(\sigma_b)_{allow}$ = allowable bending stress as defined by code specifications.

$$\frac{\sigma_a}{(\sigma_a)_{allow}} + \frac{\sigma_b}{(\sigma_b)_{allow} r^2} \leq 1$$
$$\frac{P}{(\sigma_a)_{allow}} + \frac{Mc}{(\sigma_b)_{allow} r^2} \leq 1 \quad (13 - 31)$$

13. Buckling of Columns

*13.7 DESIGN OF COLUMNS FOR ECCENTRIC LOADING

Interaction formula

- Eqn 13-31 is sometimes referred to as the interaction formula.
- This approach requires a trial-and-check procedure.
- Designer needs to choose an available column and check to see if the inequality is satisfied.
- If not, a larger section is picked and the process repeated.
- American Institute of Steel Construction specifies the use of Eqn 13-31 only when the axial-stress ratio $\sigma_a / (\sigma_a)_{\text{allow}} \leq 0.15$.

13. Buckling of Columns

EXAMPLE 13.10

Column is made of 2014-T6 aluminum alloy and is used to support an eccentric load P . Determine the magnitude of P that can be supported if column is fixed at its base and free at its top. Use Eqn 13-30.

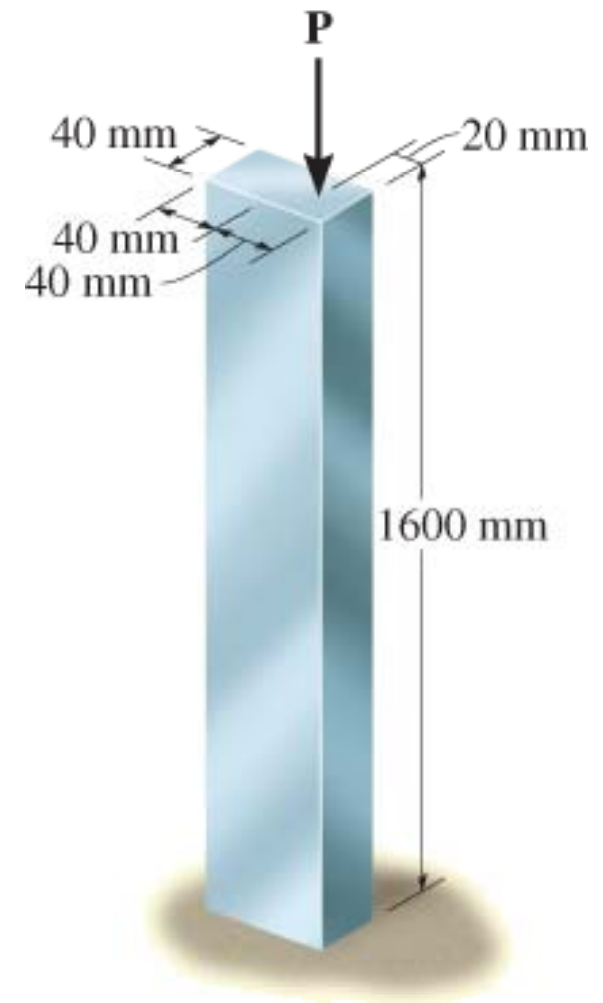

13. Buckling of Columns

EXAMPLE 13.10 (SOLN)

$K = 2$. Largest slenderness ratio for column is

$$\frac{KL}{r} = \frac{2(1600 \text{ mm})}{\sqrt{[(1/12)(80 \text{ mm})(40 \text{ mm})^3]/[(40 \text{ mm})(80 \text{ mm})]}} = 277.1$$

By inspection, Eqn 13-26 must be used ($277.1 > 55$).

$$\sigma_{\text{allow}} = \frac{378125 \text{ MPa}}{(KL/r)^2} = \frac{378125 \text{ MPa}}{(277.1)^2} = 4.92 \text{ MPa}$$

13. Buckling of Columns

EXAMPLE 13.10 (SOLN)

Actual maximum compressive stress in the column is determined from the combination of axial load and bending.

$$\begin{aligned}\sigma_{\max} &= \frac{P}{A} + \frac{(Pe)c}{I} \\ &= \frac{P}{40 \text{ mm}(80 \text{ mm})} + \frac{P(20 \text{ mm})(40 \text{ mm})}{(1/12)(40 \text{ mm})(80 \text{ mm})^3} \\ &= 0.00078125P\end{aligned}$$

Assuming that this stress is uniform over the x-section, instead of just at the outer boundary,

$$\sigma_{\text{allow}} = \sigma_{\max}; \quad 4.92 = 0.00078125P$$

$$P = 6297.6 \text{ N} = 6.30 \text{ kN}$$

13. Buckling of Columns

EXAMPLE 13.11

The A-36 steel W150×30 column is pin-connected at its ends and subjected to eccentric load P .

Determine the maximum allowable value of P using the interaction method if allowable bending stress is

$(\sigma_b)_{\text{allow}} = 160 \text{ MPa}$, $E = 200 \text{ GPa}$,
and $\sigma_Y = 250 \text{ MPa}$.

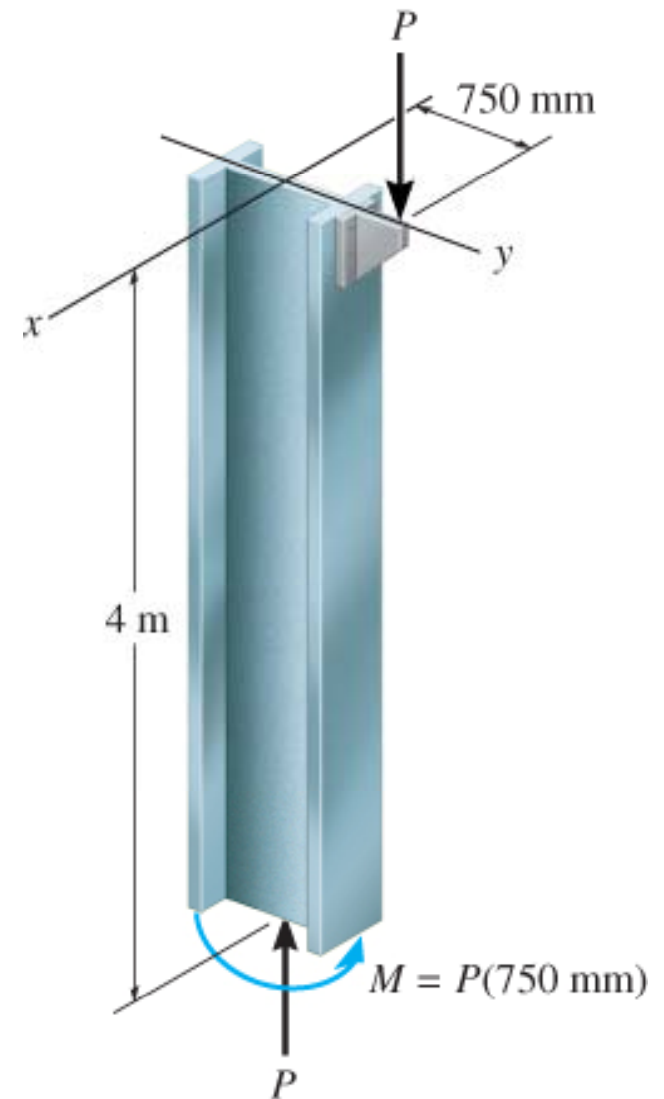

13. Buckling of Columns

EXAMPLE 13.11 (SOLN)

$K = 1$. The geometric properties for the W150×30 are taken from the table in Appendix B.

$$\begin{aligned} A &= 3790 \text{ mm}^2 & I_x &= 17.1 \times 10^6 \text{ mm}^4 \\ r_y &= 38.2 \text{ mm} & d &= 157 \text{ mm} \end{aligned}$$

We consider r_y as it lead to largest value of the slenderness ratio. I_x is needed since bending occurs about the x axis ($c = 157 \text{ mm}/2 = 78.5 \text{ mm}$). To determine the allowable bending compressive stress, we have

$$\frac{KL}{r} = \frac{1(4 \text{ m})(1000 \text{ mm/m})}{38.2 \text{ mm}} = 104.71$$

13. Buckling of Columns

Since

$$\left(\frac{KL}{r}\right)_c = \sqrt{\frac{2\pi^2 E}{\sigma_Y}} = \sqrt{\frac{2\pi^2(200)(10^3) \text{ MPa}}{250 \text{ MPa}}} = 125.66$$

then $KL/r < (KL/r)_c$ and so Eq. 13–23 must be used.

13. Buckling of Columns

EXAMPLE 13.11 (SOLN)

Then $KL/r < (KL/r)_c$ and so Eqn 13-23 must be used.

$$\begin{aligned}\sigma_{\text{allow}} &= \frac{\left[1 - \frac{(104.71)^2}{2(125.66)^2}\right] \cdot 250 \text{ MPa}}{\left\{\left(\frac{5}{3}\right) + \left[\frac{3(104.71)}{8(125.66)}\right] - \left[\frac{(104.71)^3}{8(125.66)^3}\right]\right\}} \\ &= 85.59 \text{ MPa}\end{aligned}$$

Assuming that this stress is uniform over the x-section, instead of just at the outer boundary,

13. Buckling of Columns

EXAMPLE 13.11 (SOLN)

Applying the interaction formula Eqn 13-31 yields

$$\frac{\sigma_a}{(\sigma_a)_{allow}} + \frac{\sigma_b}{(\sigma_b)_{allow}} \leq 1$$

$$\frac{P / 3790 \text{ mm}^2}{85.59 \text{ N/mm}^2} + \frac{P(750 \text{ mm})(157 \text{ mm} / 2) / 17.1(10^6) \text{ mm}^4}{160 \text{ N/mm}^2} = 1$$

$$P = 40.65 \text{ kN}$$

Checking application of interaction method for steel section, we require

$$\frac{\sigma_a}{\sigma_{allow}} = \frac{40.65(10^3) \text{ N} / (3790 \text{ mm}^2)}{85.59 \text{ N/mm}^2} = 0.125 < 0.15 \text{ OK!}$$

13. Buckling of Columns

EXAMPLE 13.12

Timber column is made from two boards nailed together so the x-section has the dimensions shown.

If column is fixed at its base and free at its top, use Eqn 13-30 to determine the eccentric load P that can be supported.

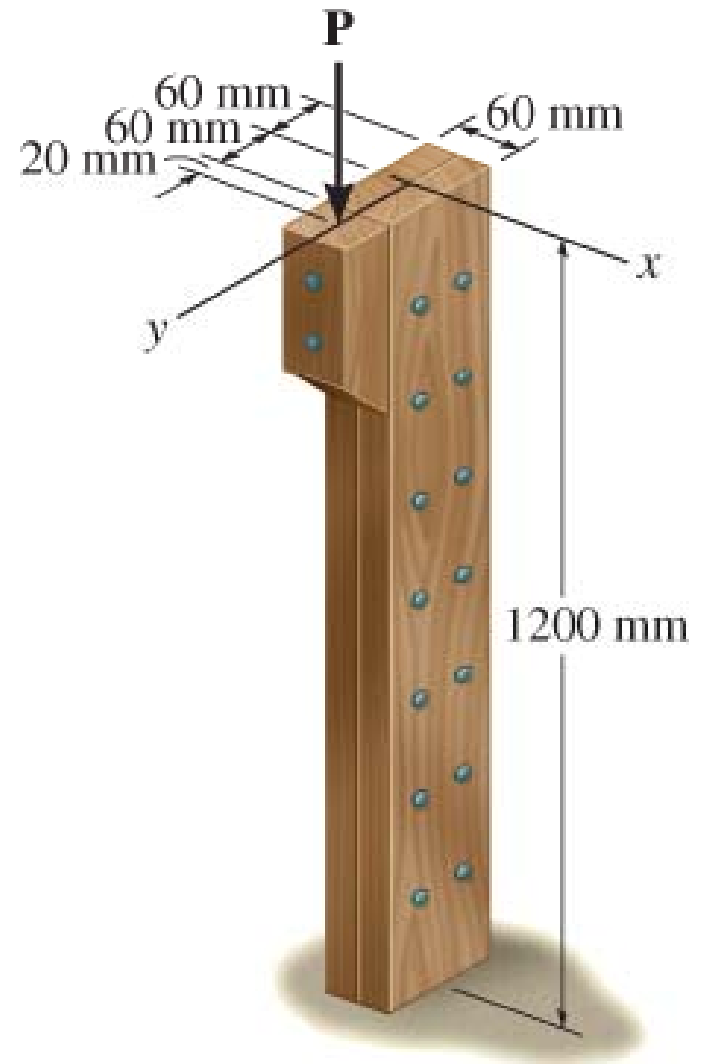

13. Buckling of Columns

EXAMPLE 13.12 (SOLN)

$K = 2$. Here, we calculate KL/d to determine which eqn to use. Since σ_{allow} is determined using the largest slenderness ratio, we choose $d = 60$ mm.

This is done to make the ratio as large as possible, and thus yield the lowest possible allowable axial stress.

This is done even though bending due to P is about the x axis.

$$\frac{KL}{d} = \frac{2(1200 \text{ mm})}{60 \text{ mm}} = 40$$

13. Buckling of Columns

EXAMPLE 13.12 (SOLN)

Allowable axial stress is determined using Eqn 13-29 since $26 < KL/d < 50$. Thus

$$\sigma_{allow} = \frac{3718 \text{ MPa}}{(KL/d)^2} = \frac{3718 \text{ MPa}}{(40)^2} = 2.324 \text{ MPa}$$

Applying Eqn 13-30 with $\sigma_{allow} = \sigma_{max}$, we have

$$\sigma_{allow} = \frac{P}{A} + \frac{Mc}{I}$$
$$2.324 \text{ N/mm}^2 = \frac{P}{60 \text{ mm}(120 \text{ mm})} + \frac{P(80 \text{ mm})(60 \text{ mm})}{(1/12)(600 \text{ mm})(120 \text{ mm})^3}$$
$$P = 3.35 \text{ kN}$$

13. Buckling of Columns

CHAPTER REVIEW

- Buckling is the sudden instability that occurs in columns or members that support an axial load.
- The maximum axial load that a member can support just before buckling occurs is called the critical load P_{cr} .
- The critical load for an ideal column is determined from the Euler eqn, $P_{cr} = \pi^2 EI / (KL)^2$, where $K = 1$ for pin supports, $K = 0.5$ for fixed supports, $K = 0.7$ for a pin and a fixed support, and $K = 2$ for a fixed support and a free end.