

Adaptive Filter

A digital filter that automatically **adjusts its coefficients** to adapt input signal **via an adaptive algorithm**.

Applications:

- **Signal enhancement**
- **Active noise control**
- **Noise cancellation**
- **Telephone echo cancellation**

Text: Digital Signal Processing
by Li Tan, Chapter 10

Simplest Noise Canceller

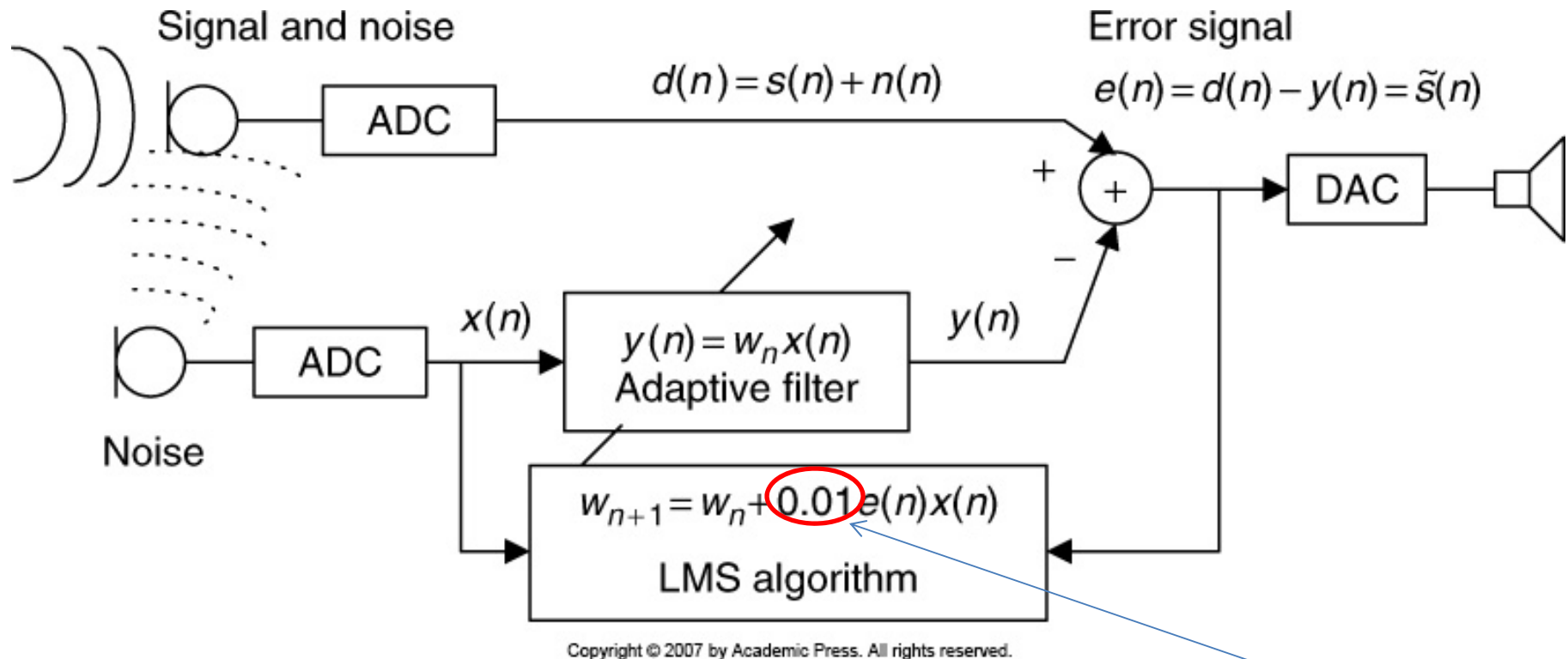

$n(n)$ is a linear filtered (delayed) version of $x(n)$.

Controls speed of convergence

Simplest Noise Canceller - contd.

$$y(n) = w_n x(n)$$

$$e(n) = d(n) - y(n)$$

Initial coefficient $w_0 = 0.3$

$$w_{n+1} = w_n + 0.01e(n)x(n).$$

n	$d(n)$	$x(n)$
0	-0.2947	-0.5893
1	1.0017	0.5893

← Measured

$$n = 0, \quad y(0) = w_0 x(0) = 0.3 \times (-0.5893) = -0.1768$$

$$e(0) = d(0) - y(0) = -0.2947 - (-0.1768) = -0.1179 = \tilde{s}(0)$$

$$w_1 = w_0 + 0.01e(0)x(0) = 0.3 + 0.01 \times (-0.1179) \times (-0.5893) = 0.3007$$

$$n = 1, \quad y(1) = w_1 x(1) = 0.3007 \times 0.5893 = 0.1772$$

$$e(1) = d(1) - y(1) = 1.0017 - 0.1772 = 0.8245 = \tilde{s}(1)$$

$$w_2 = w_1 + 0.01e(1)x(1) = 0.3007 + 0.01 \times 0.8245 \times 0.5893 = 0.3056$$

Wiener Filter & LMS Algorithm

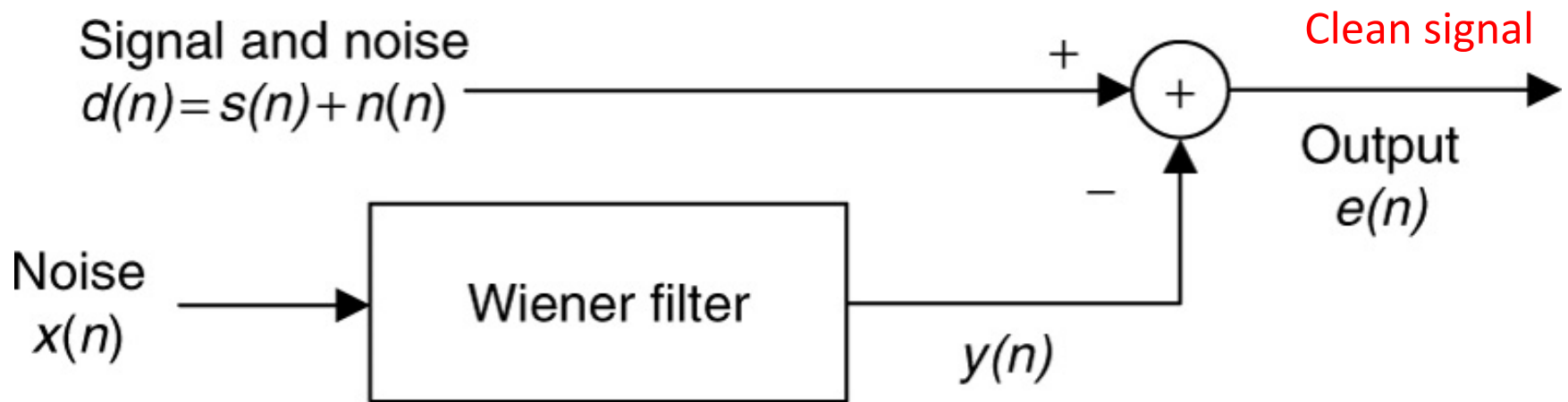

Copyright © 2007 by Academic Press. All rights reserved.

Consider, single weight case, $y(n) = wx(n)$.

Error signal, $e(n) = d(n) - wx(n)$

Now we have to solve for the best weight w^*

$$e^2(n) = (d(n) - wx(n))^2 = d^2(n) - 2d(n)wx(n) + w^2x^2(n)$$

LMS Algorithm

Taking Expectation of squared error signal

$$E(e^2(n)) = E(d^2(n)) - 2wE(d(n)x(n)) + w^2E(x^2(n))$$

$$J = E(e^2(n)) = \text{MSE (mean squared error)}$$

$$\sigma^2 = E(d^2(n)) = \text{power of corrupted signal}$$

$$P = E(d(n)x(n)) = \text{cross-correlation between } d(n) \text{ and } x(n)$$

$$R = E(x^2(n)) = \text{autocorrelation}$$

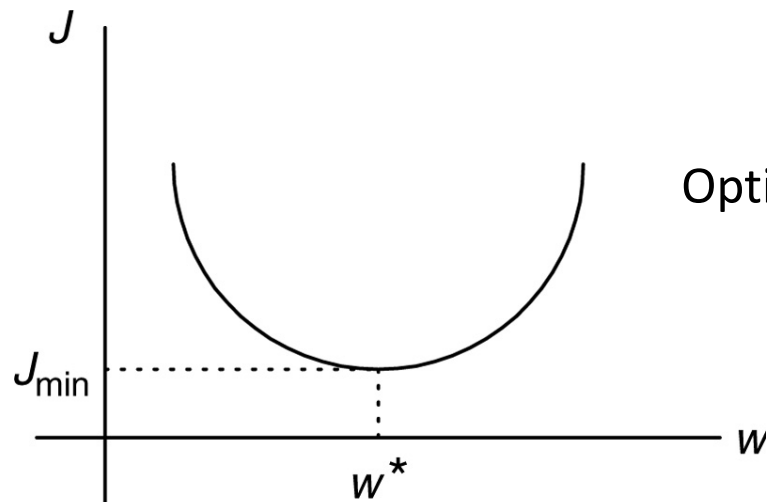

For large N, $J = \sigma^2 - 2wP + w^2R$

Optimal w^* is found when minimum J is achieved

$$\frac{dJ}{dw} = -2P + 2wR = 0.$$

$$w^* = R^{-1}P$$

LMS Algorithm - Example

Given MSE function for the Wiener filter:

$$\frac{dJ}{dw} = -20 + 10 \times 2w = 0$$

Solving for optimal, we get $w^* = 1$

Finally we get

$$J_{\min} = J|_{w=w^*} = 40 - 20w + 10w^2|_{w=1} = 40 - 20 \times 1 + 10 \times 1^2 = 30$$

large N

$$w^* = R^{-1}P$$

R^{-1} : Matrix inversion

Makes real-time implementation difficult

Steepest Decent Algorithm

$$w_{n+1} = w_n - \mu \frac{dJ}{dw}$$

μ = constant controlling the speed of convergence.

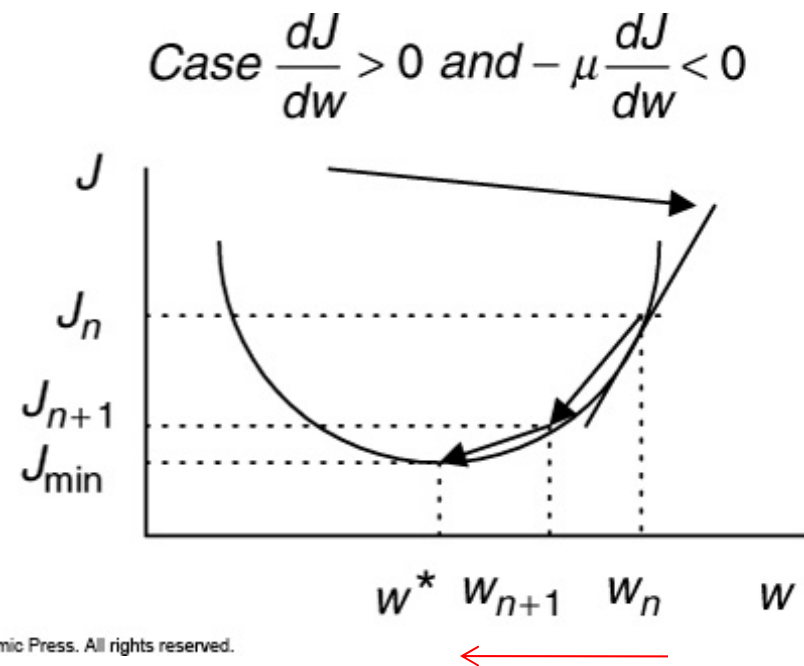
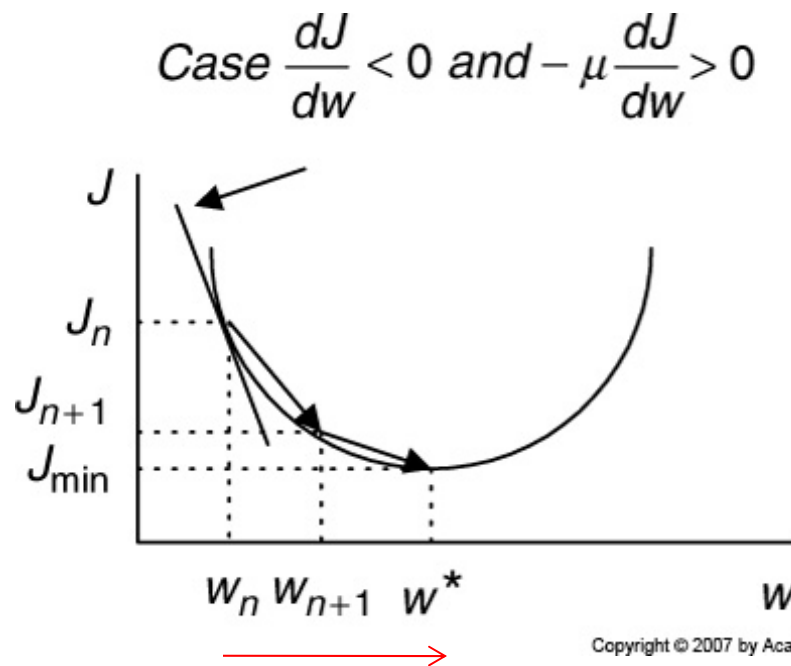

Copyright © 2007 by Academic Press. All rights reserved.

Steepest Decent Algorithm: Example

Given: $J = 40 - 20w + 10w^2$
 $\mu = 0.04$ $w_0 = 0$
Iteration three times

Find optimal solution for w^*

Solution:

$$\frac{dJ}{dw} = -20 + 10 \times 2w_n$$

For $n = 0$,

$$\mu \frac{dJ}{dw} = 0.04 \times (-20 + 10 \times 2w_0)|_{w_0=0} = -0.8$$

$$w_1 = w_0 - \mu \frac{dJ}{dw} = 0 - (-0.8) = 0.8$$

For $n = 1$,

$$\mu \frac{dJ}{dw} = 0.04 \times (-20 + 10 \times 2w_1)|_{w_1=0.8} = -0.16$$

$$w_2 = w_1 - \mu \frac{dJ}{dw} = 0.8 - (-0.16) = 0.96$$

For $n = 2$,

$$\mu \frac{dJ}{dw} = 0.04 \times (-20 + 10 \times 2w_2)|_{w_2=0.96} = -0.032$$

$$w_3 = w_2 - \mu \frac{dJ}{dw} = 0.96 - (-0.032) = 0.992.$$

$$J_{\min} \approx 40 - 20w + 10w^2|_{w=0.992} \\ = 30.0006$$

$$w^* \approx w_3 = 0.992$$

Steepest Decent Algorithm - contd1.

To make it sample-based processing, we need to take out estimation.

$$J = e^2(n) = (d(n) - wx(n))^2$$
$$\frac{dJ}{dw} = 2(d(n) - wx(n)) \frac{d(d(n) - wx(n))}{dw} = -2e(n)x(n)$$

Updating weight $w_{n+1} = w_n + 2\mu e(n)x(n)$

For multiple tap FIR filter:

$$y(n) = w_n(0)x(n) + w_n(1)x(n-1) + \dots + w_n(N-1)x(n-N+1)$$

for $i = 0, \dots, N-1$

$$w_{n+1}(i) = w_n(i) + 2\mu e(n)x(n-i).$$

Choose convergence constant as

$$0 < \mu < \frac{1}{NP_x}$$

P_x : maximum input power

Steepest Decent Algorithm - contd2.

Steps:

1. Initialize $w(0), w(1), \dots, w(N - 1)$ to arbitrary values.

2. Read $d(n), x(n)$, and perform digital filtering:

$$y(n) = w(0)x(n) + w(1)x(n - 1) + \dots + w(N - 1)x(n - N + 1).$$

3. Compute the output error:

$$e(n) = d(n) - y(n).$$

4. Update each filter coefficient using the LMS algorithm:

for $i = 0, \dots, N - 1$

$$w(i) = w(i) + 2\mu e(n)x(n - i).$$

Noise Canceller Using Adaptive Filter-1

Perform adaptive filtering to obtain outputs $e(n) = n = 0, 1, 2$

Given: $x(0) = 1, x(1) = 1, x(2) = -1,$

$d(0) = 2, d(1) = 1, d(2) = -2$

Initial weights: $w(0) = w(1) = 0,$

$\mu = 0.1$

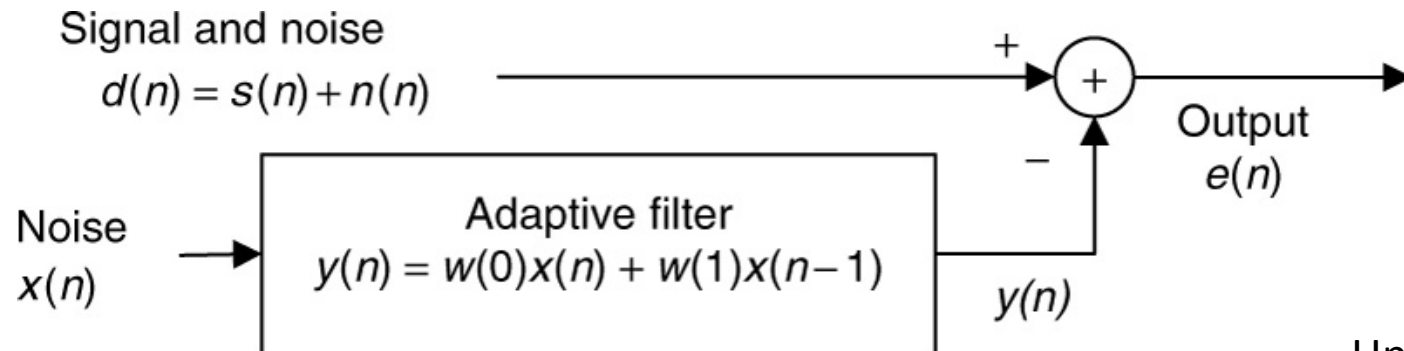

Updating weights:

Solution:

Filtering: $y(n) = w(0)x(n) + w(1)x(n - 1)$

Output: $e(n) = d(n) - y(n)$

$$w(0) = w(0) + 2\mu e(n)x(n)$$

$$w(1) = w(1) + 2\mu e(n)x(n - 1)$$

Noise Canceller Using Adaptive Filter-2

For $n = 0$

Digital filtering:

$$y(0) = w(0)x(0) + w(1)x(-1) = 0 \times 1 + 0 \times 0 = 0$$

Computing the output:

$$e(0) = d(0) - y(0) = 2 - 0 = 2$$

Updating coefficients:

$$w(0) = w(0) + 2 \times 0.1 \times e(0)x(0) = 0 + 2 \times 0.1 \times 2 \times 1 = 0.4$$

$$w(1) = w(1) + 2 \times 0.1 \times e(0)x(-1) = 0 + 2 \times 0.1 \times 2 \times 0 = 0.0$$

For $n = 1$

Digital filtering:

$$y(1) = w(0)x(1) + w(1)x(0) = 0.4 \times 1 + 0 \times 1 = 0.4$$

Computing the output:

$$e(1) = d(1) - y(1) = 1 - 0.4 = 0.6$$

Updating coefficients:

$$w(0) = w(0) + 2 \times 0.1 \times e(1)x(1) = 0.4 + 2 \times 0.1 \times 0.6 \times 1 = 0.52$$

$$w(1) = w(1) + 2 \times 0.1 \times e(1)x(0) = 0 + 2 \times 0.1 \times 0.6 \times 1 = 0.12$$

Noise Canceller Using Adaptive Filter-3

For $n = 2$

Digital filtering:

$$y(2) = w(0)x(2) + w(1)x(1) = 0.52 \times (-1) + 0.12 \times 1 = -0.4$$

Computing the output:

$$e(2) = d(2) - y(2) = -2 - (-0.4) = -1.6$$

Updating coefficients:

$$w(0) = w(0) + 2 \times 0.1 \times e(2)x(2) = 0.52 + 2 \times 0.1 \times (-1.6) \times (-1) = 0.84$$

$$w(1) = w(1) + 2 \times 0.1 \times e(2)x(1) = 0.12 + 2 \times 0.1 \times (-1.6) \times 1 = -0.2.$$

Output (noise-cleaned signal):

$$e(0) = 2, e(1) = 0.6, e(2) = -1.6$$

Practice: Textbook by Li Tan, Chapter 10.

10.3, 10.5, 10.7

Digital Signal Processors - Introduction

Processors dedicated to DSP

Off-line processing: all the data needs to be in the memory at the same time. The output is produced after all the input data is in the memory.

On-line processing: the output is produced as the same time the input is coming. No delay or little delay.

Circular Buffer Operation:

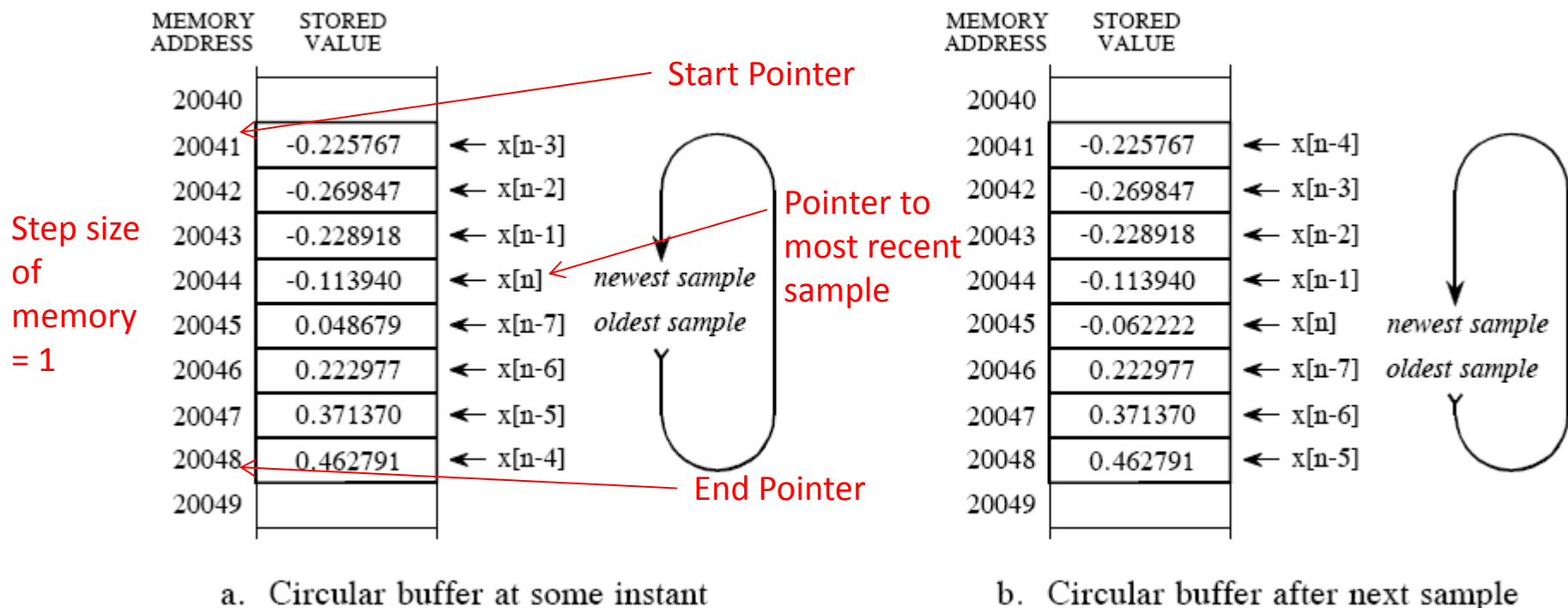

Microprocessors Architecture

Normal microprocessors



a. Von Neumann Architecture (*single memory*)

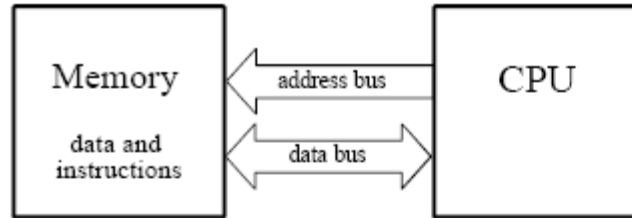

DSP uses these ideas



b. Harvard Architecture (*dual memory*)

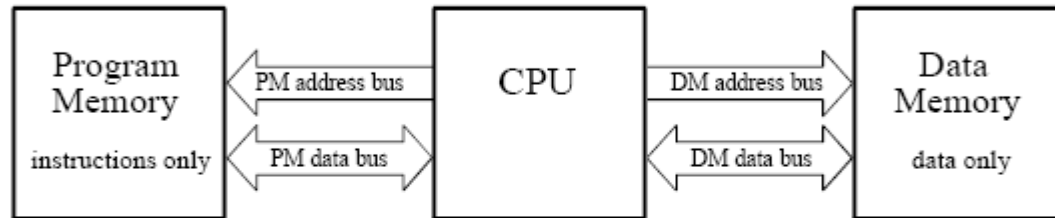

c. Super Harvard Architecture (*dual memory, instruction cache, I/O controller*)

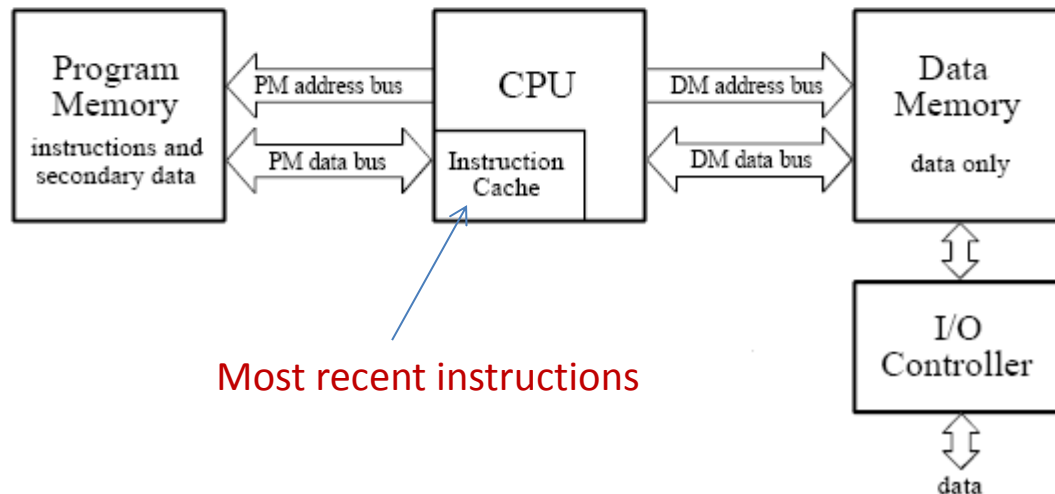

Most recent instructions

Typical DSP Architecture

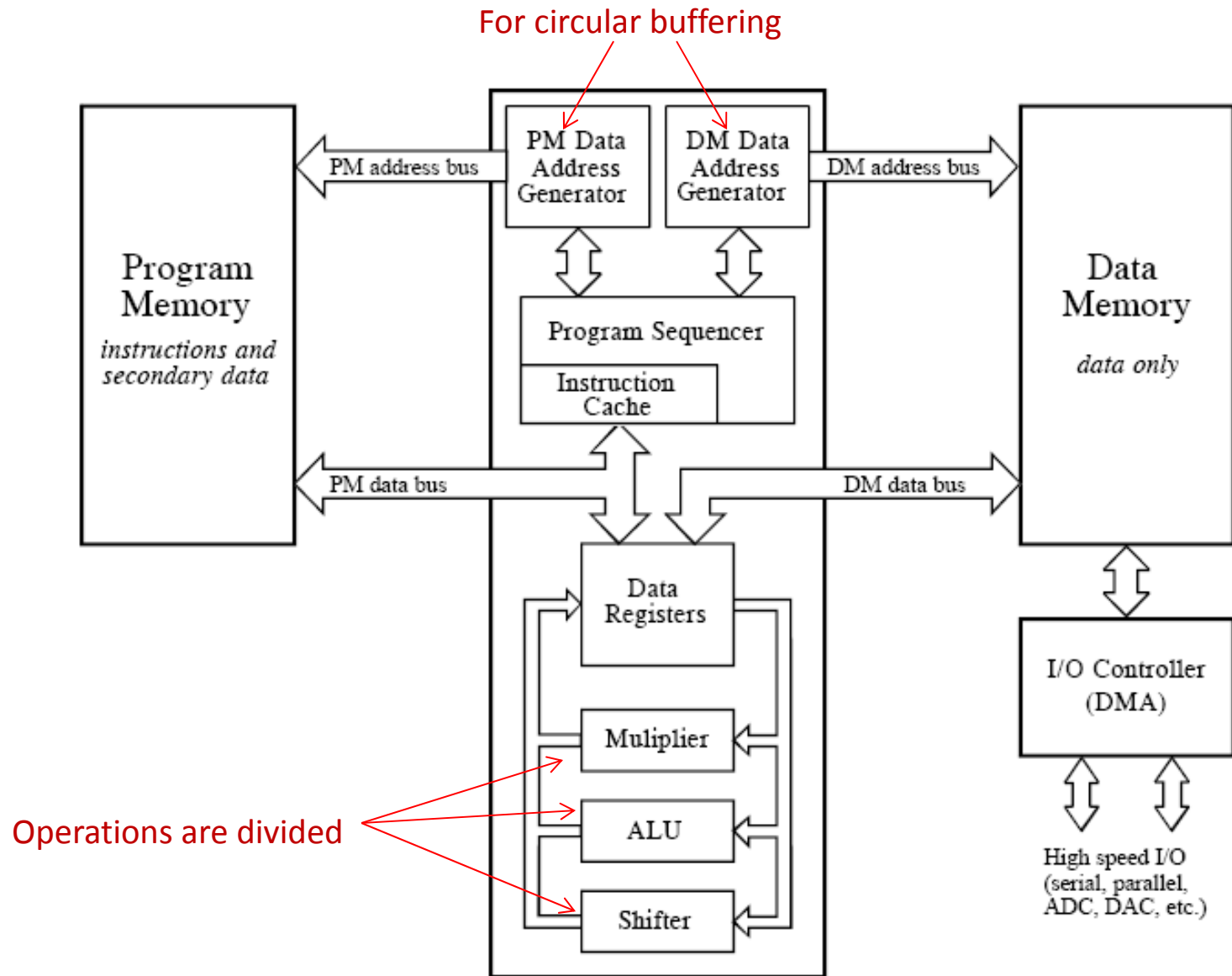

Application of DSP in Image Processing: Basic Intensity Transfer Functions

- Linear
- Logarithmic
- Power-law

Grey Image has intensity in the range $[0 - 255]$ i.e. it uses 8 bits.

Intensity is transformed for better viewing.

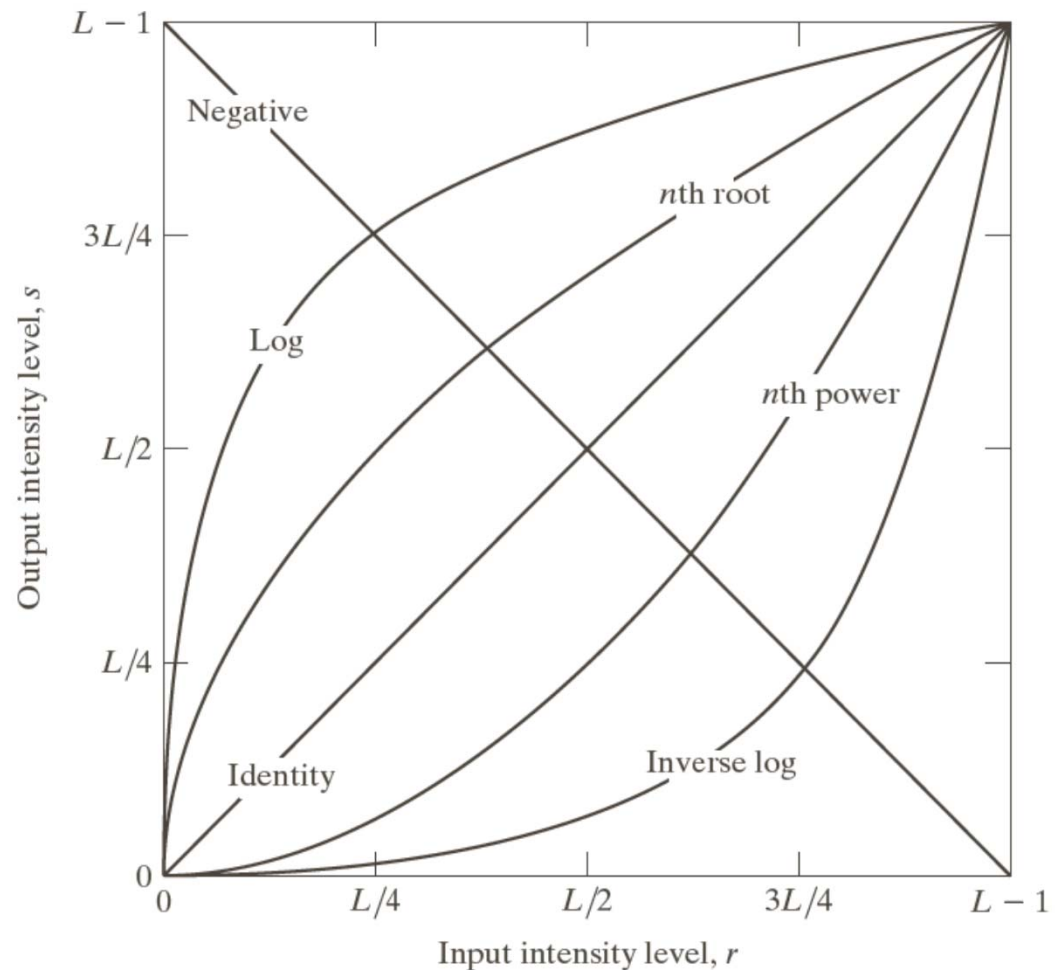

Negative Transformation

Intensity level: $[0, L - 1]$

$$s = L - 1 - r$$

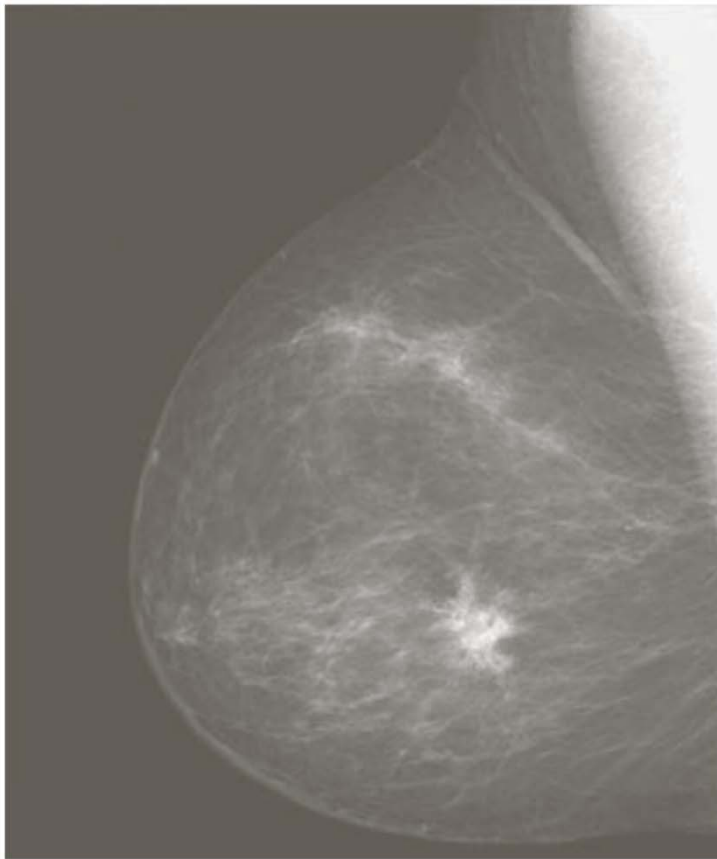

Original Image



Negative Image

Log Transformation

$$s = c \log(1 + r)$$

Compresses the dynamic range of images with large variations in pixel values.

Loss of details in low pixel values

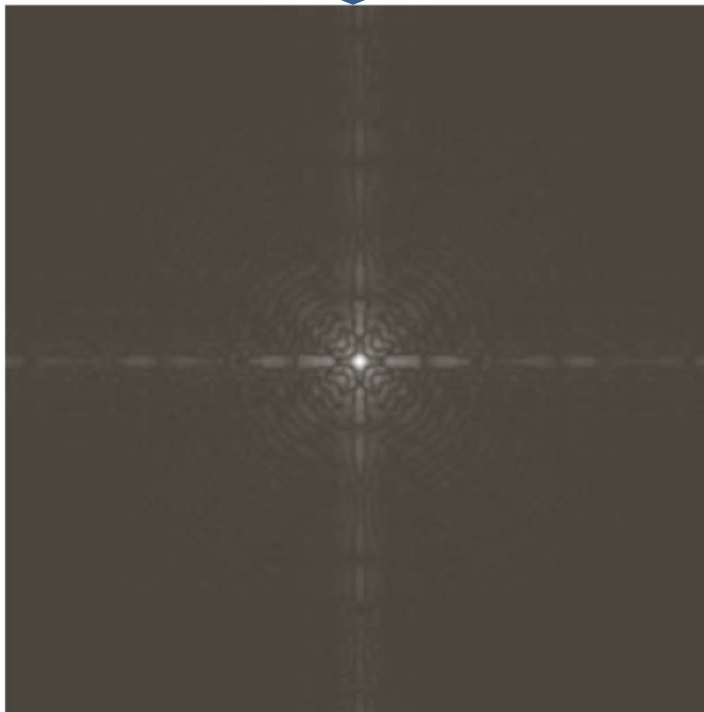

Original Image (Fourier Spectrum)

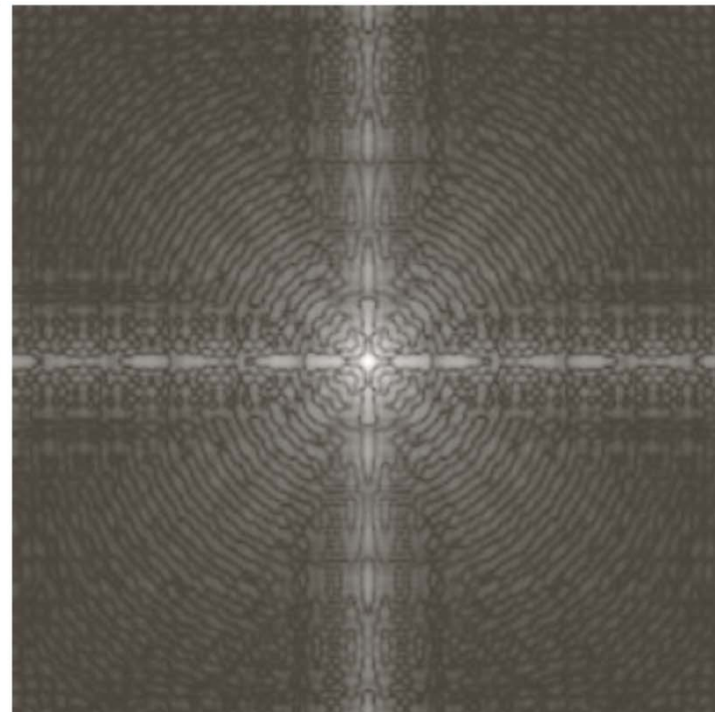

Log Transformed Image

Contrast manipulation: Power-Law

MRI of a fractured spine.

$$s = cr^\lambda$$



$\lambda = 0.6$

$\lambda = 0.4$

Best contrast



$\lambda = 0.3$

Washed out

Filter Mask

w_1	w_2	w_3
w_4	w_5	w_6
w_7	w_8	w_9

$$R = w_1 z_1 + w_2 z_2 + \dots + w_9 z_9 = \sum_{k=1}^9 w_k z_k = \mathbf{w}^T \mathbf{z}$$

Smoothing Filter (low pass) mask:

 $\frac{1}{9} \times$

1	1	1
1	1	1
1	1	1



Equal weight

 $\frac{1}{16} \times$

1	2	1
2	4	2
1	2	1



Weighted average

$$g(x, y) = \frac{\sum_{s=-a}^a \sum_{t=-b}^b w(s, t) f(x + s, y + t)}{\sum_{s=-a}^a \sum_{t=-b}^b w(s, t)}$$



Normalization factor

Smoothing Effect

Original image

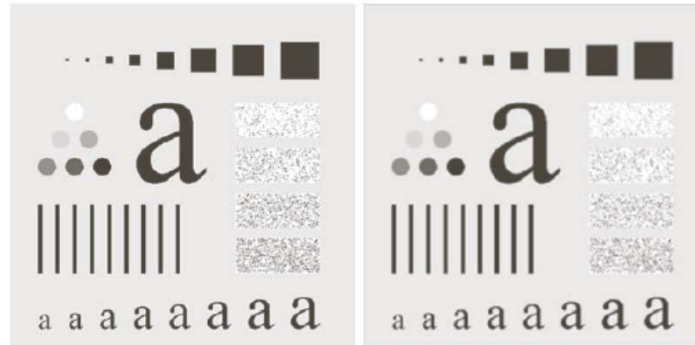

3 X 3 mask

Noise is less pronounced.

5 X 5 mask

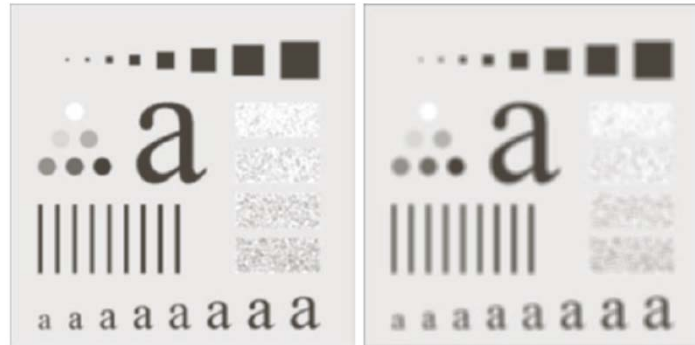

35 X 35 mask

Completely blurred!



Median Filtering

Find the median in the neighborhood, then assign the center pixel value to that median.

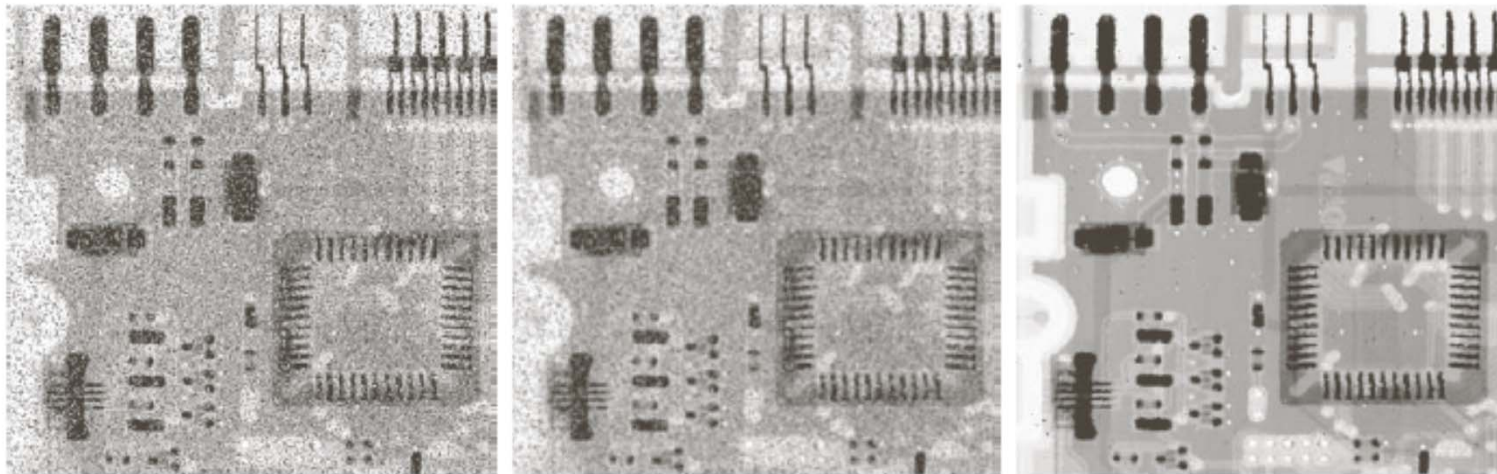

a b c

FIGURE 3.35 (a) X-ray image of circuit board corrupted by salt-and-pepper noise. (b) Noise reduction with a 3×3 averaging mask. (c) Noise reduction with a 3×3 median filter. (Original image courtesy of Mr. Joseph E. Pascente, Lixi, Inc.)

Digital (Image) Watermarking

Inserting information (watermark) into images in such a way that the watermark is inseparable from the images.

- Copyright identification.
- User identification.
- Authenticity determination.
- Automated monitoring.
- Copy protection.

$$f_w = (1 - \alpha)f + \alpha w$$

Watermarked image

Original image

Watermark

Example of Watermarking - I

Visible



a
b c

FIGURE 8.50

A simple visible watermark:
(a) watermark;
(b) the watermarked image; and (c) the difference between the watermarked image and the original (non-watermarked) image.

$\alpha = 0.3$

Example of Watermarking - II

Invisible

Watermark is inserted in image's two LSBs.

$$f_w = 4 \left(\frac{f}{4} \right) + \frac{w}{64}$$

Sets two LSBs of image to 00.

Shifts two MSBs into two LSBs.

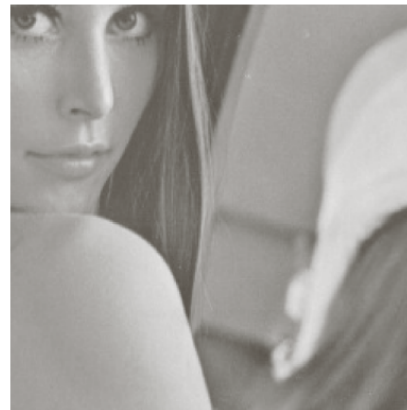

By zeroing 6 MSB and scaling the remains to full intensity level, we get

←
Digital Image Processing

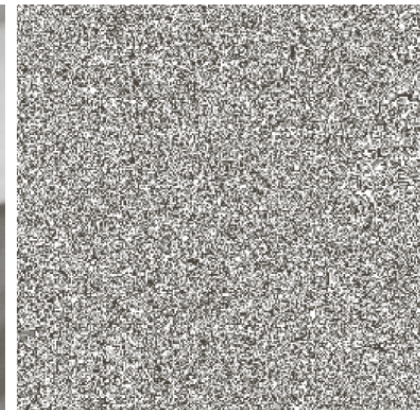
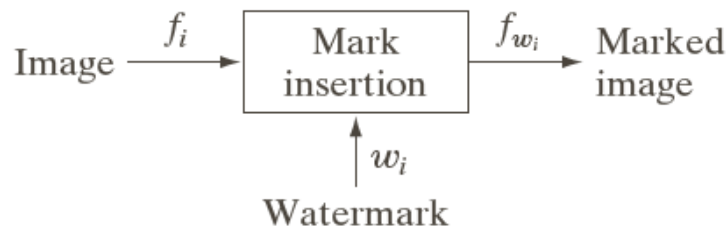
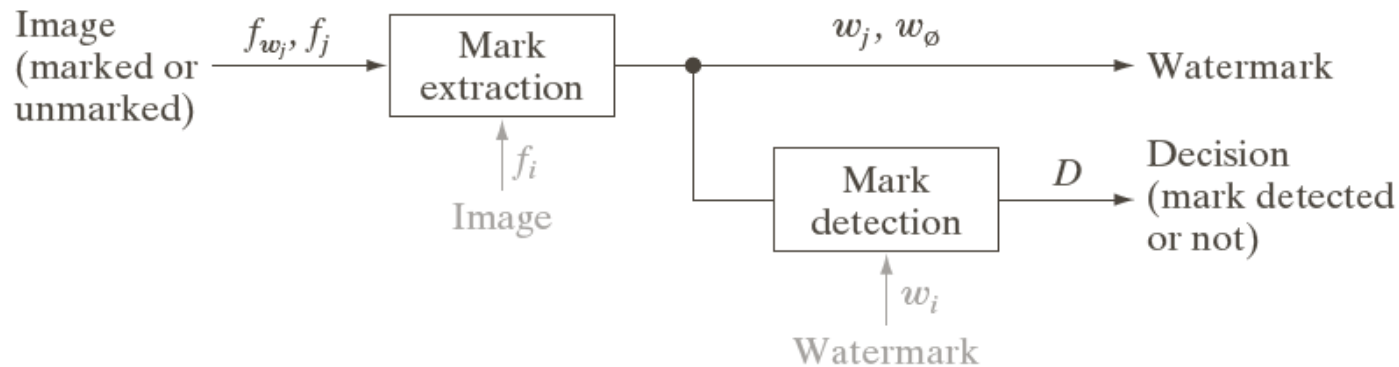

Image Watermarking System



a
b

FIGURE 8.52
A typical image watermarking system:
(a) encoder;
(b) decoder.



Private / restricted key system: f_i and w_i are used.

Public / unrestricted key system: f_i and w_i are unused.