

Tutorial 2

4.38

The mass of the crane's boom is 9000 kg. Its weight acts at G. The sum of the moment about P due to the boom's weight, the force exerted at B by the cable AB, and the force exerted at C by the cable AC is zero. Assume the tension on cables AB and AC are equal. Determine the tension in the cables.

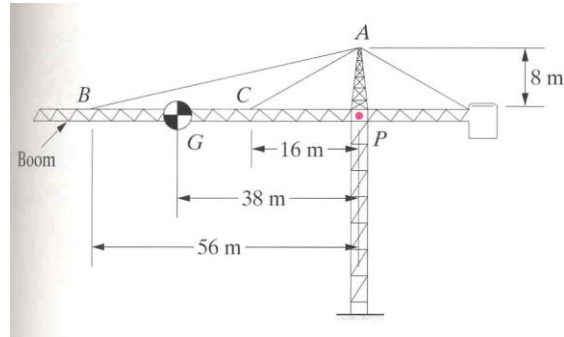

4.105

Replace the force and couple system by an equivalent force and couple moment acting at point P.

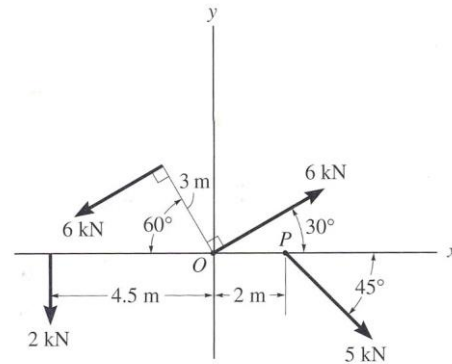

4.107

Replace the force and couple system by an equivalent force and couple moment at point P.

