

King Saud University

College of Engineering

IE – 462: “Industrial Information Systems”

Spring – 2021 (2<sup>nd</sup> Sem. 1442H)

Chapter 4:

*Structured Analysis and Functional  
Architecture Design – p1 – IDEF0 – ii – Case Study*

Prepared by: Ahmed M. El-Sherbeeney, PhD

# Lesson Overview

- Modeling IIS – (p1)
- Integrated Computer-Aided Manufacturing Definition 0 (IDEF0) – (p1)
- Data Flow Diagram (DFD) – (p2)

# Functional Modeling

## Integrated Computer-Aided Manufacturing Definition 0 (IDEF0) – cont'd

# An Integrated IDEF0 Model of an Entire Manufacturing Enterprise

- Top-level view of the enterprise: Node A0

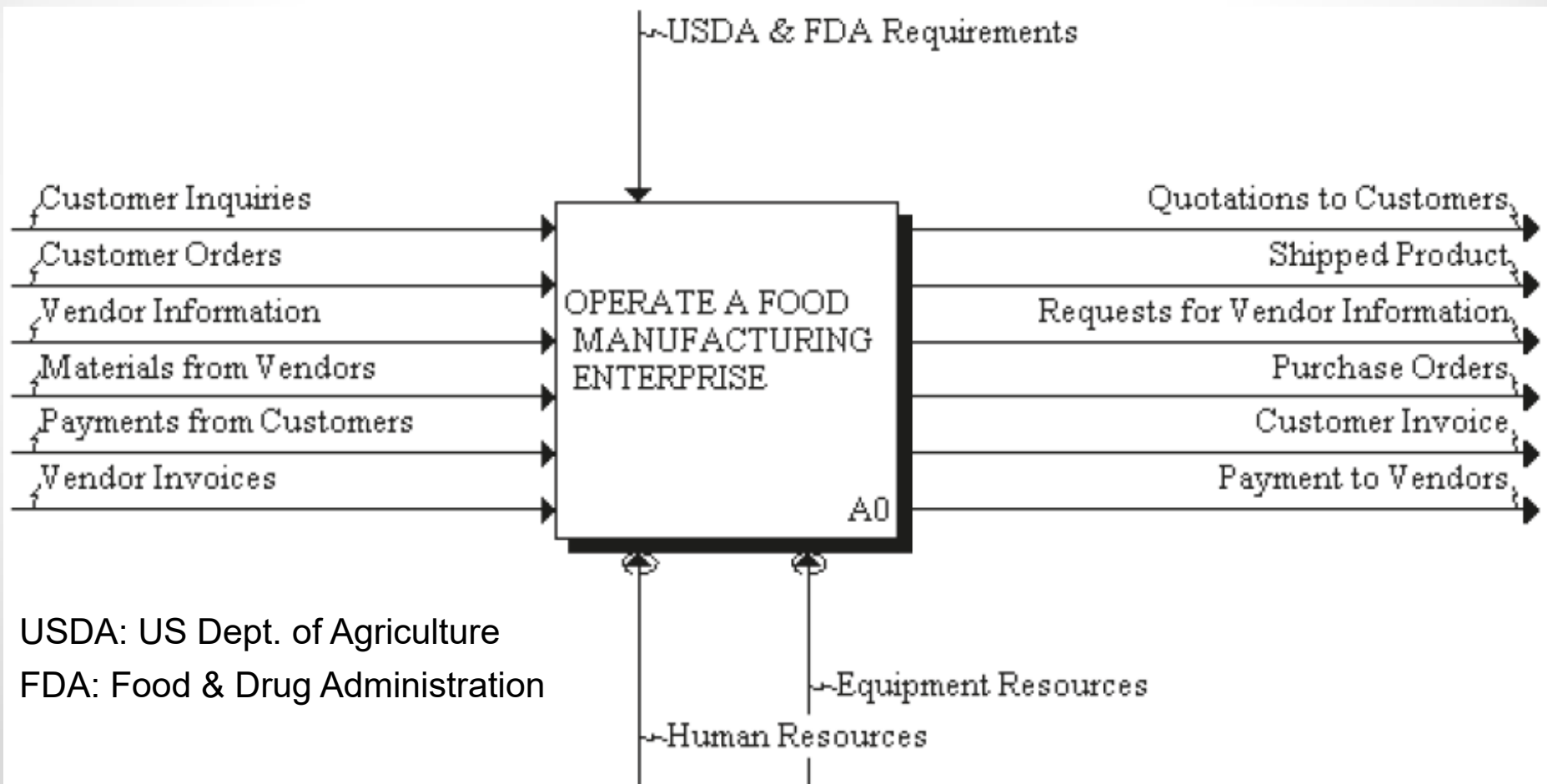

# Decomposition of Node A0

Breakdown structure:

A0 — Operate a Food Manufacturing Enterprise

A1 — Manage Sales and Order Process

A2 — Plan for Manufacture

A3 — Manufacture Product

A4 — Control Finished Goods

# Decomposition of Node A0 – cont.

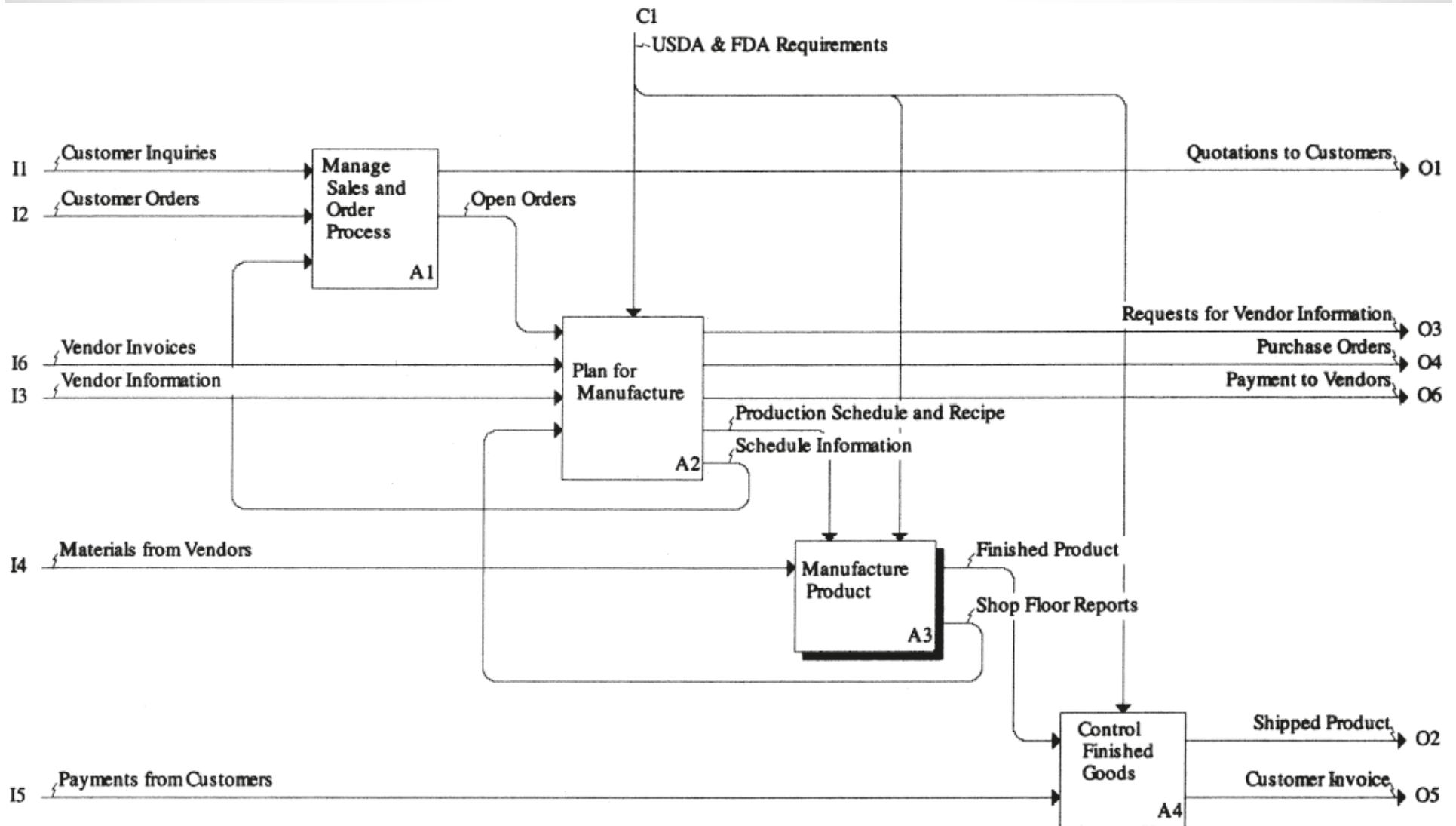

# Decomposition of Node A3

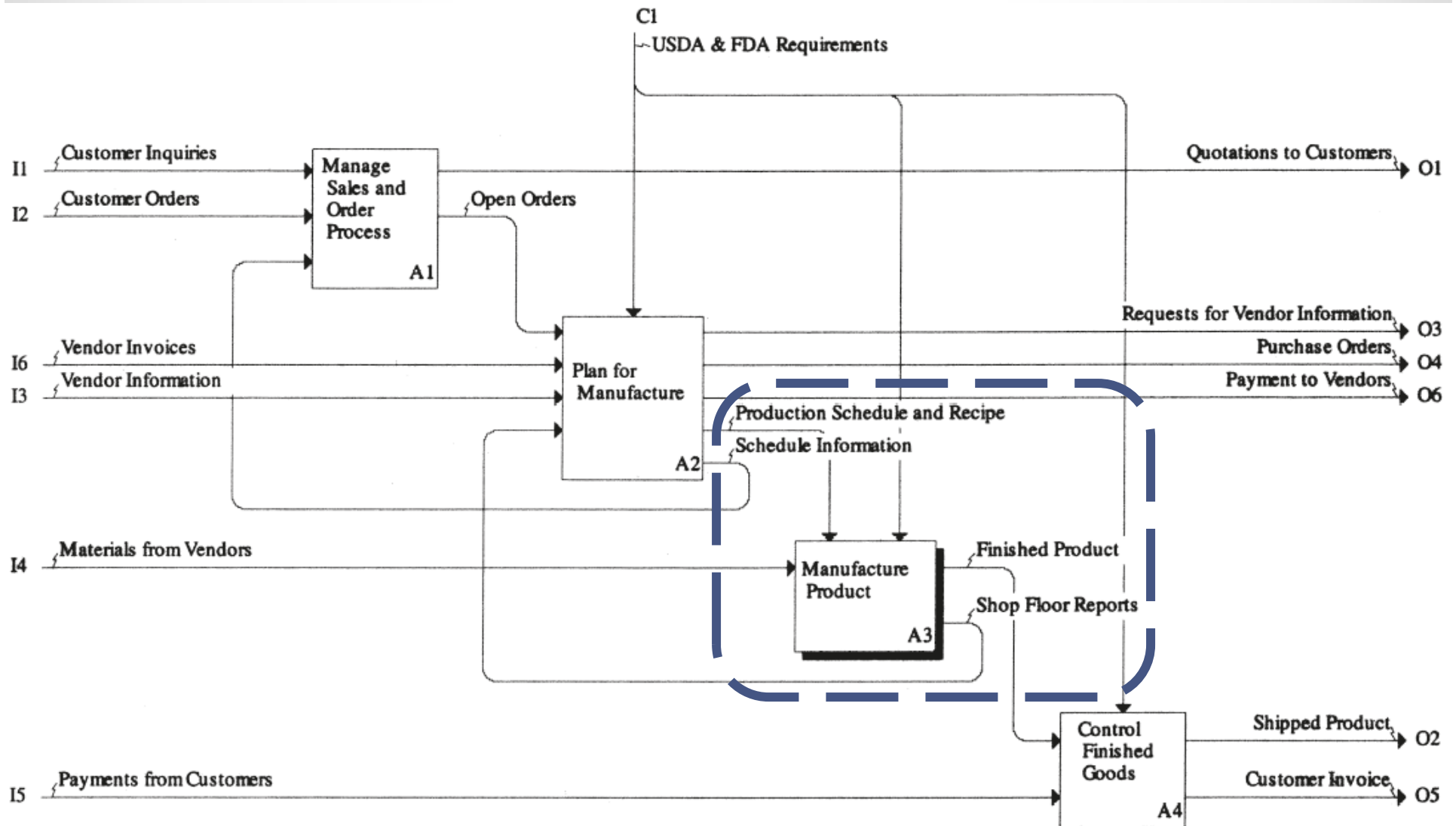

## Decomposition of Node A3 – cont.

A0 — Operate a Food Manufacturing Enterprise

A1 — Manage Sales and Order Process

A2 — Plan for Manufacture

A3 — Manufacture Product

**A31 — Control Incoming Materials**

**A32 — Control Stored Material**

**A33 — Control Production Processes**

A4 — Control Finished Goods



# Decomposition of Node A3 – cont.

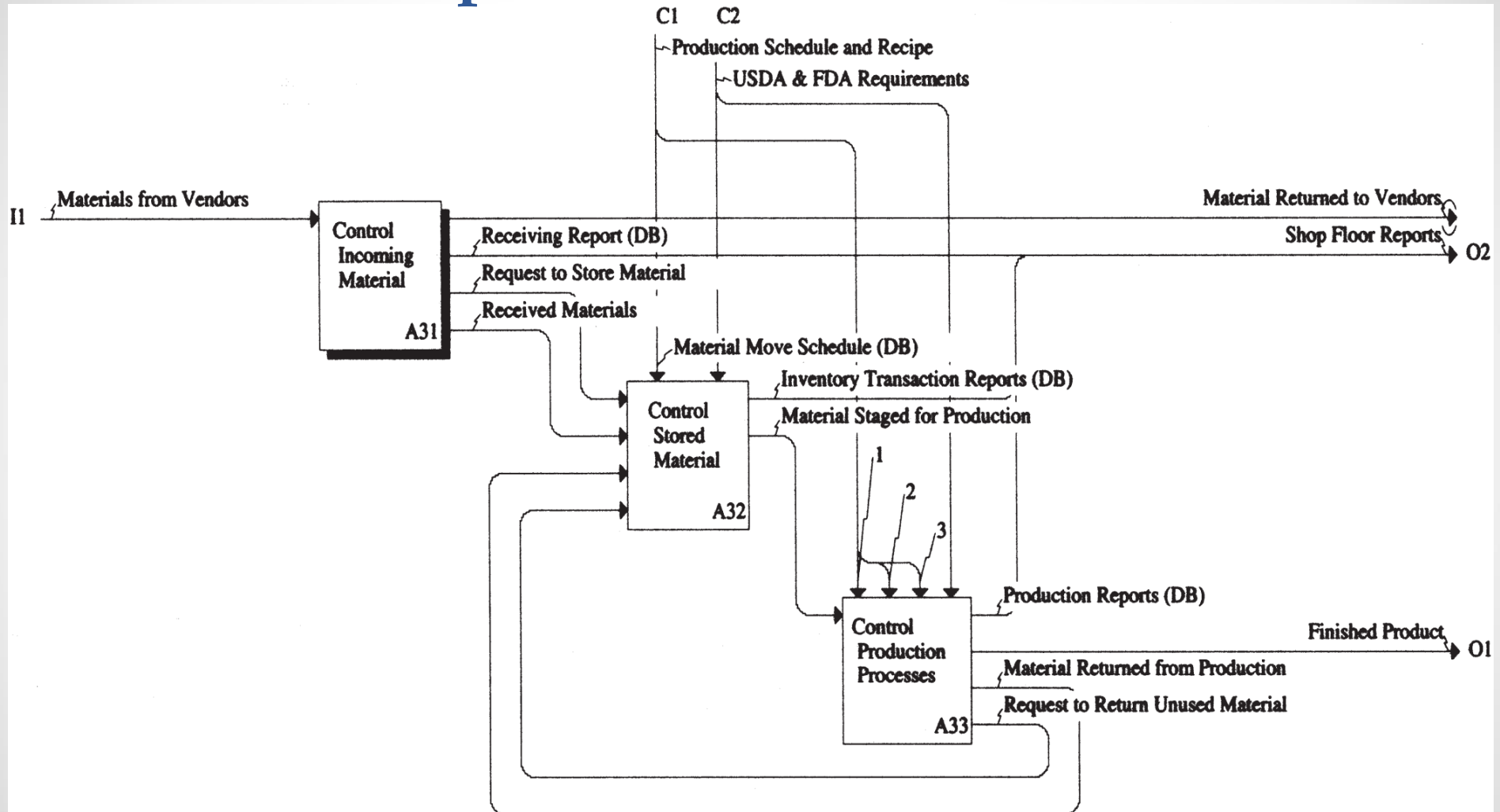

- 1 - Retort Processing Information (DB)
- 2 - Cook Sheet (DB)
- 3 - Day Production Schedule (DB)

## Decomposition of Node A3 – cont.

### Concept of tunneling

- e.g. output of activity A31, labeled “Material Returned to Vendors”
  - Note the *tunnel* on the *arrowhead* of the arc
- A tunnel arrow can represent:
  - (1) an *external* arrow that did not appear in the parent diagram (i.e. it has a hidden source) or,
  - (2) an arrow that goes to another activity but does not appear explicitly on the destination activity (i.e. a hidden destination)
- Tunneling is used when it is not convenient to show all I’s, O’s, controls, or mechanisms at every level of the hierarchy

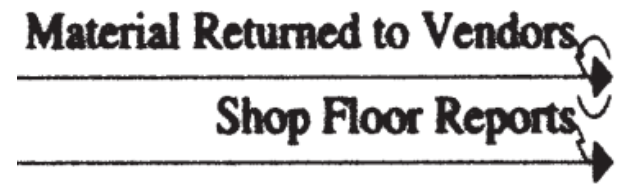

# Decomposition of Node A3 – cont.

## Concept of **bundling**

- e.g. node A2 provides a control for activity node A3 called “[production schedule and recipe](#)”
- Production schedule:
  - Daily schedule for production of a particular product
- Recipe includes:
  - Steps in the production process
  - Materials/ingredients used at each step to make the product, and
  - Critical operating parameters of the production line (e.g. temperatures, time settings for cooking and sterilization)

## Decomposition of Node A3 – cont.

Production schedule and recipe **documents**:

### **(1) retort processing information:**

“retort”: chamber of superheated water for sterilizing packaged food products

### **(2) cook sheet:**

formula that must be used for each product; includes ingredients and equipment settings

### **(3) day production schedule:**

which production lines will be used to produce each of the products to be made that day, and order of production (for multiple products)

### **(4) material move schedule:**

tells forklift truck operator which lots of ingredients to transfer from storage to production

## Decomposition of Node A3 – cont.

Indication of **DB** on control documents

- DB: database
- This informs reader that this is information that is derived from some data source (e.g. electronic)
- Note, this notation is not part of the IDEF0 methodology (only added here for convenience)

# Decomposition of Node A31

## Elemental nodes

- Elemental level is the most detailed level of analysis of functions
- We will focus on node A31, "Control Incoming Material"
- Elemental nodes:
  - should be prepared with those individuals within the enterprise who are *actors* in the process
  - should give clear conceptual understanding of the processes that are taking place and
  - should give information requirements at each stage of the process
  - elemental nodes are described in detail in next slides

# Decomposition of Node A31

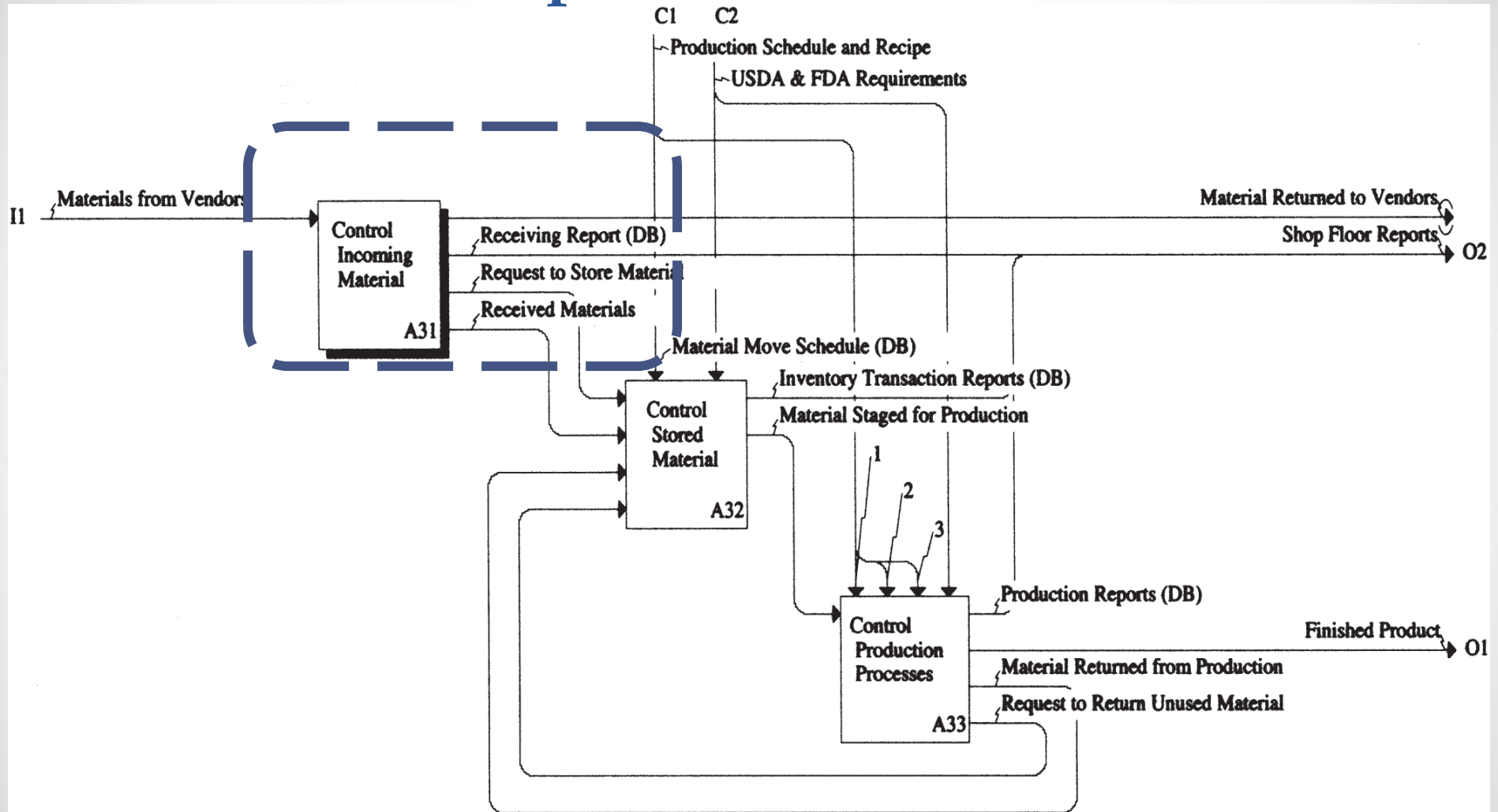

- 1 - Retort Processing Information (DB)
- 2 - Cook Sheet (DB)
- 3 - Day Production Schedule (DB)

## Decomposition of Node A31

A0 — Operate a Food Manufacturing Enterprise

A1 — Manage Sales and Order Process

A2 — Plan for Manufacture

A3 — Manufacture Product

A31 — Control Incoming Materials

**A311 — Confirm Validity of Shipment**

**A312 — Inspect Condition of Materials**

**A313 — Receive Materials**

A32 — Control Stored Material

A33 — Control Production Processes

A4 — Control Finished Goods



# Decomposition of Node A31

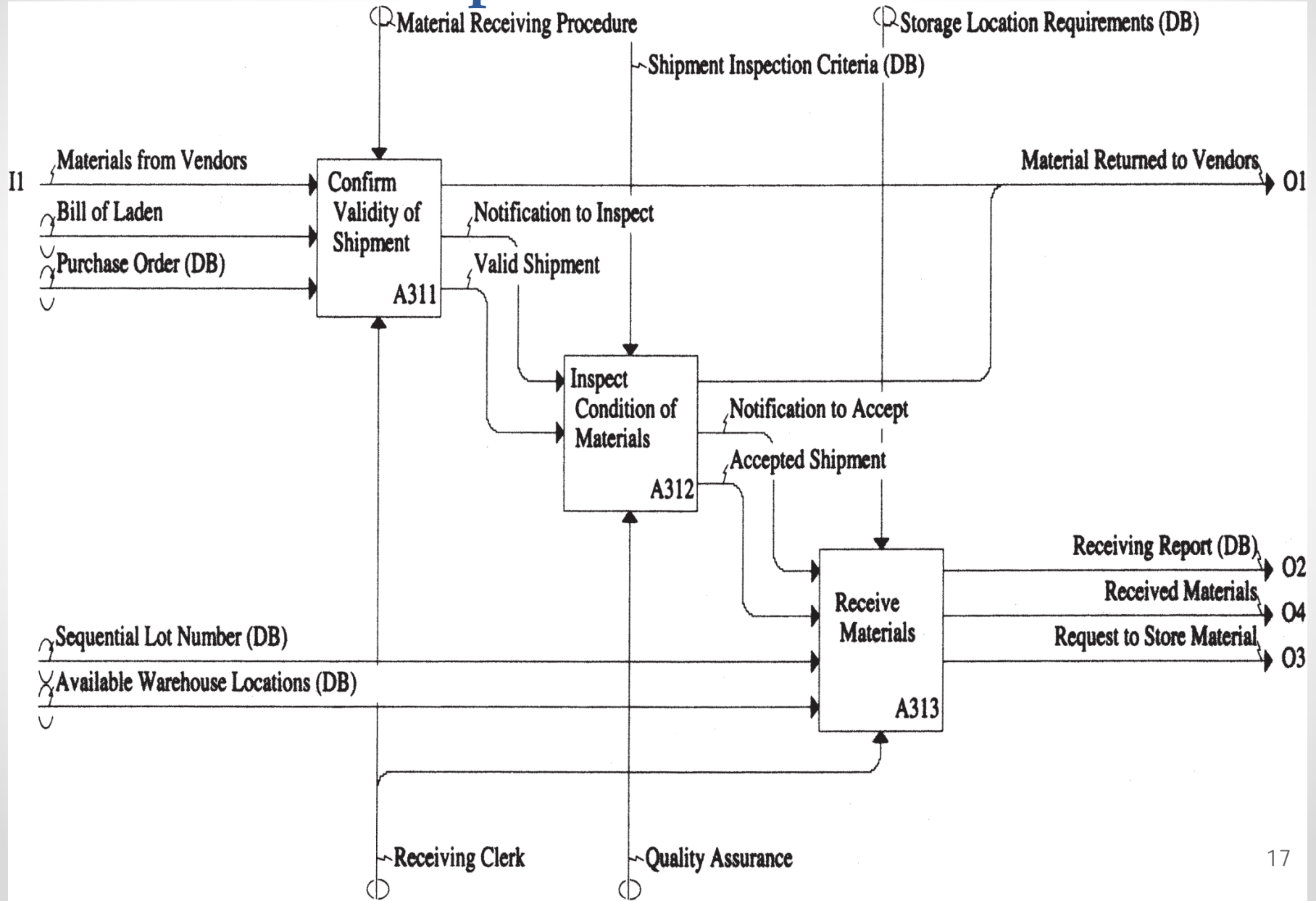

# Decomposition of Node A31

- Node A311: Confirm validity of shipment
  - Try to trace the story/narrative here on the decomposition chart
  - First, the shipment arrives
  - The receiving clerk (note the [mechanism arc](#)) compares,
    - paperwork that comes with the shipment (**bill of laden**) with the
    - enterprise's **purchase order** (PO)
  - If the material in the [2 inputs](#) (BOL and PO) are matching ⇒ shipment is accepted
    - otherwise, the shipment is refused (return to vendor)
  - This procedure is defined as the “**material receiving procedure**” (by the enterprise management)

# Decomposition of Node A31

- Node A312: Inspect condition of material
  - Receiving clerk notifies **quality assurance** (QA) that material has arrived
  - ⇒ QA personnel examine condition of truck contents (using **shipment inspection criteria**):
    - e.g. broken containers can result in a partial/total rejection of the shipment
  - Note, this is not an inspection of the quality of individual materials
    - such testing is performed in **quality control** (QC) lab *after* the material is stored in the warehouse and *before* it is used in production
  - When quality assurance clears the shipment for acceptance, the receiving clerk is notified

# Decomposition of Node A31

- Node A313: Receive materials
  - Record of shipments: on a form called a **receiving report**

RECEIVING REPORT						
Supplier: <b>General Provisions</b>				Purchase Order No.: <b>PO3502</b>		
<b>125 Common St.</b>				Date Received: <b>June 25 2006</b>		
<b>Boise, ID 44830</b>						
Quantity		Mfg. Lot No.	Item Code	Mat'L Lot No.	Description	Storage Location
accepted	not accepted					
1000		1275	RM805	97275	Tomato Paste, 1 gallon cans	Area A, Aisle 1 tier 1, bins 10-18
300		1283	"	97276	" " " "	Area A, Aisle 1 Tier 2, Bins 10-13
	100	"	"		" " " "	returned <sup>(1)</sup>
<b>Comments: (1) returned due to case damage and badly dented containers.</b> Received by: <i>J. Debbis</i>						

# Decomposition of Node A31

- Node A313: Receive materials (contd.)
  - Upon accepting shipment, the receiving clerk:
    - shipment is unloaded and made available for storage
    - assigns lot numbers to accepted material
    - lot numbers are assigned as sequential numbers and obtained by the clerk from a data source (DB)
    - clerk also assigns material to storage location based on material location requirements/location availability
    - forklift truck operator is informed of the location to which the material should be moved (indicated by the output arrow "Request to Store Raw Materials")

# Sources

- [Design of Industrial Information Systems](#). Thomas Boucher, and Ali Yalcin. Academic Press. First Ed. 2006. Chapter 4.
- Some useful videos:
  - Function modelling using IDEF0: The basics of functions, inputs, outputs, mechanisms and controls (<https://youtu.be/xyO5n6Ay-1I>)
  - AI0Win Tutorial – “Manage a Coffee Shop” (<https://youtu.be/kHDNIFclsiY>)