

Computer Programming-1

CSC 111

Chapter 1 : Introduction

Chapter Outline

- What a computer is
- What a computer program is
- The Programmer's Algorithm
- How a program that you write in Java is changed into a form that your computer can understand
- Characteristics of Java

What Is a Computer?

- Computer
 - Executes statements (computations/logical decisions)
- Hardware :Physical devices of computer system
- Software: Programs that run on computers

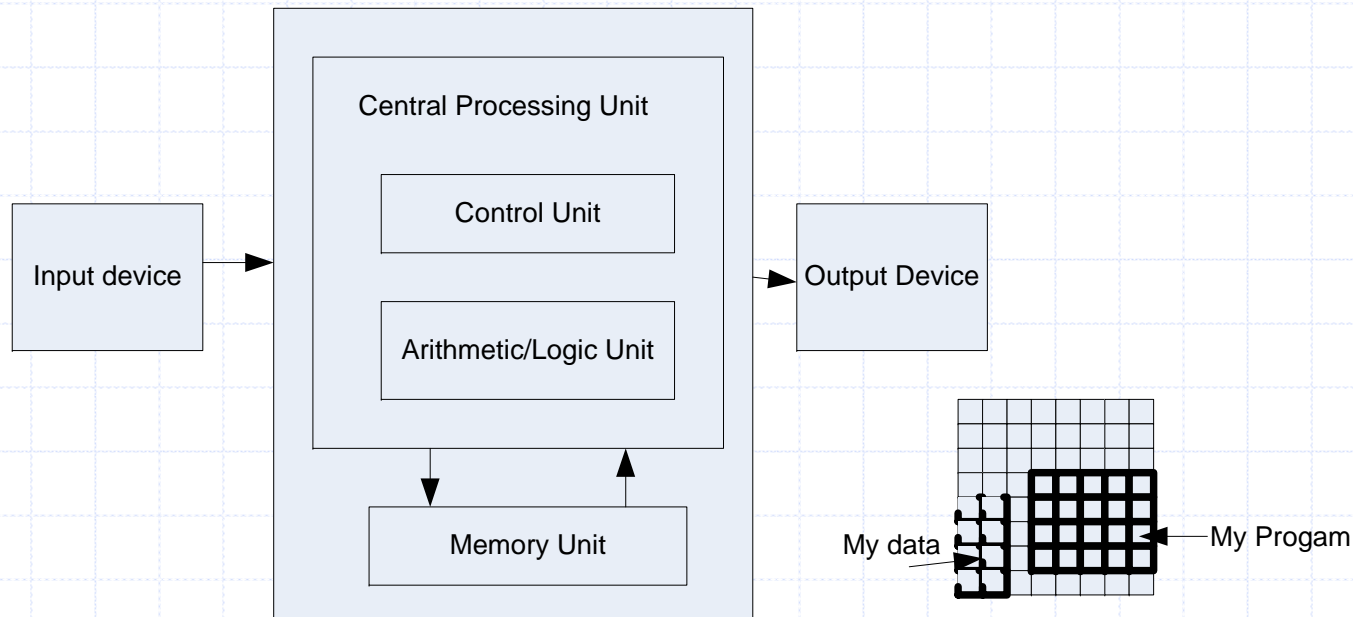

Computer Organization

- Six logical units of computer system
 - Input unit (Mouse, keyboard)
 - Output unit (Printer, monitor, audio speakers)
 - Memory unit (Retains input and processed information)
 - Central processing unit (CPU) which consists of:
 - Control unit (Supervises operation of other devices)
 - Arithmetic and logic unit (ALU) (Performs calculations)
 - Secondary storage unit (Hard drives, floppy drives)

What a computer program is?

- For a computer to be able to perform specific tasks (i.e. print what grade a student got on an exam), it must be given instructions to do the task.
- The set of instructions that tells the computer to perform specific tasks is known as a *computer program*

Levels of Abstraction

- Human thought
- Pseudo-Natural Language (English, Arabic)
- High Level Programming Language (C, C++, Java, ...)
- Machine Code

The Programmer's Algorithm

- **An algorithm** is a finite sequence of instructions that produces a solution to a problem.
- **The programmer's algorithm:**
 - Define the problem.
 - Plan the problem solution.
 - Code the program.
 - Compile the program.
 - Run the program.
 - Test and debug the program.

Defining the Problem

- The problem must be defined in terms of:
 - **Input:** Data to be processed.
 - **Output:** The expected result.
 - Look for nouns in the problem statement that suggest output and input.
 - and **processing:** The statements to achieve.
 - Look for verbs to suggest processing steps.

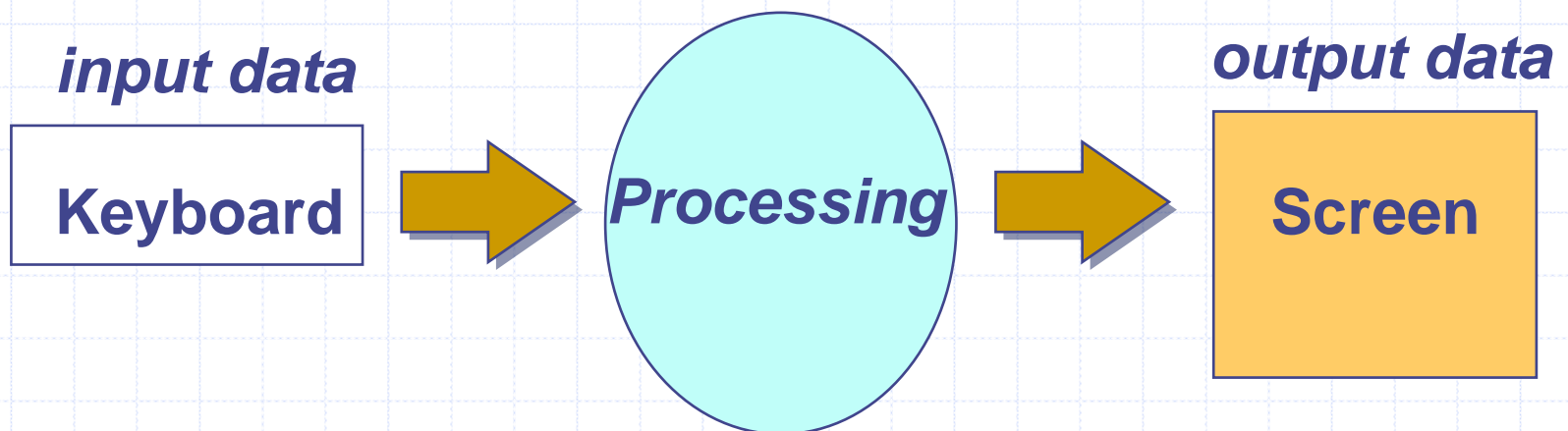

Input and Output

- **Inputs**

- Can come from many sources, such as users, files, and other programs
- Can take on many forms, such as text, graphics, and sound

- **Outputs**

- Can also take on many forms, such as numbers, text, graphics, sounds, or commands to other programs

Example 1

Area and Perimeter of a rectangle

- **Input**
 - Length
 - width
- **Processing**
 - Area = length*width
 - Perimeter = $2 * (\text{length} + \text{width})$
- **Output**
 - Area
 - Perimeter

Example 2

Sum and Average of 5 numbers

- **Input**
 - five number x_1, x_2, x_3, x_4, x_5
- **Processing**
 - $\text{Sum} = x_1 + x_2 + x_3 + x_4 + x_5$
 - $\text{Average} = \text{Sum}/5$
- **Output**
 - Sum
 - Average

Example 3

Area and Perimeter of a circle

- **Input**
 - Radius
 - PI
- **Processing**
 - Area = $PI * Radius * Radius$
 - Perimeter = $2 * PI * Radius$
- **Output**
 - Area
 - Perimeter

Planning the Solution

- When planning, algorithms are used to outline the solution steps using **Englishlike statements**, called *pseudocode*.

Coding the Program

- Coding is writing the program in a formal language called **Programming Language**.
 - **Programming Language** : A set of rules, symbols and special words used to write statements.
- The program is written by translating the algorithm steps into a programming language statements.
- The written program is called ***Source code*** and it is saved in a file with ".java" extension.

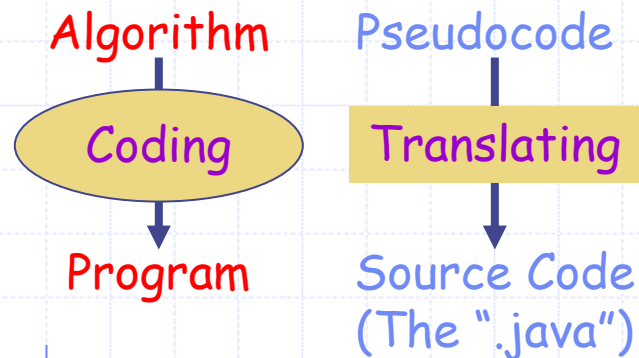

Why Coding in Programming Languages

- We write computer programs (i.e. a set of instructions) in programming languages such as C, C++, and Java.
- We use these programming languages because they are easily understood by humans
- But then how does the computer understand the instructions that we write?

Compiling Computer Programs

- *Computers do not understand* programs written in *programming languages* such as C++ and Java
- Programs must first be *converted into machine code* that the computer can run
- A Software that *translates* a programming language statements into machine code is called a *compiler*

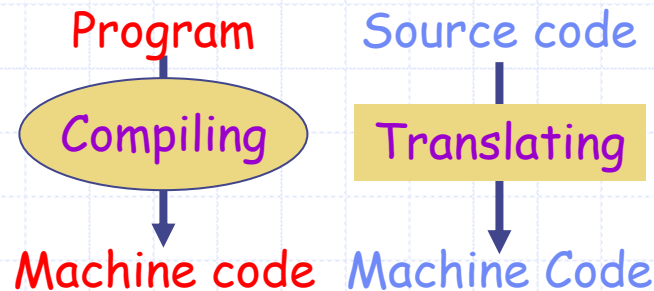

Programming Language Compiler

- A compiler is a software that:
 - *Checks the correctness* of the source code according to the language rules.
 - **Syntax errors** are raised if some rules were violated.
 - *Translates* the source code into a machine code if no errors were found.

Platform dependent Compiling

- Because different *platforms*, or hardware architectures along with the operating systems (Windows, Macs, Unix), require different machine code, you must compile most programs separately for each platform.

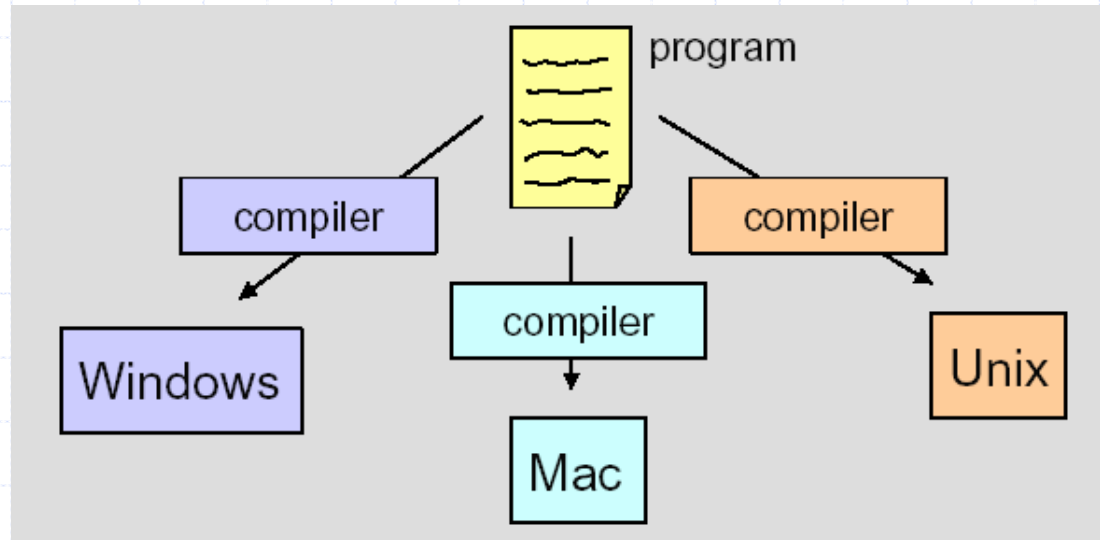

Compiling Java Programs

- The Java compiler produces *bytecode* (a *“.class” file*) not machine code from the source code (the *“.java” file*).
- Bytecode is converted into machine code using a *Java Interpreter*

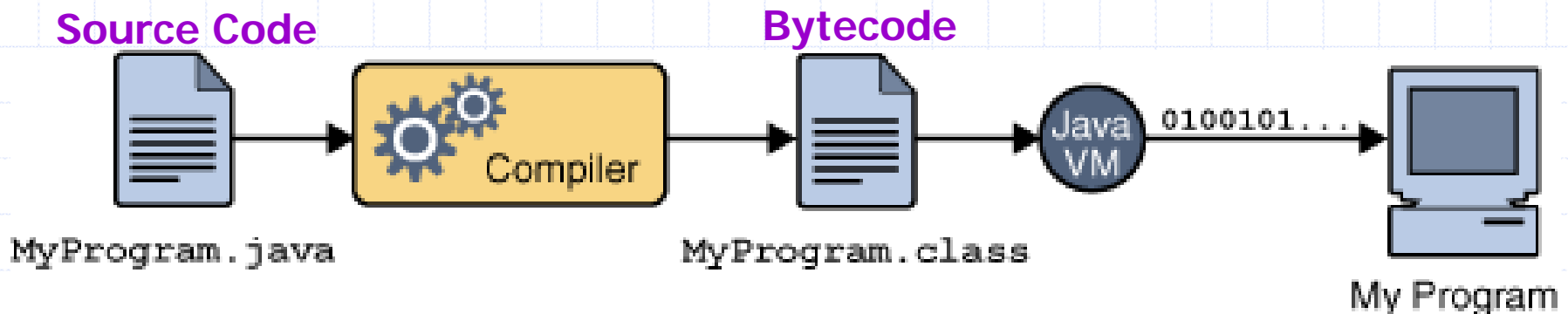

Platform Independent Java Programs Compiling

- You can run bytecode on an computer that has a Java Interpreter installed

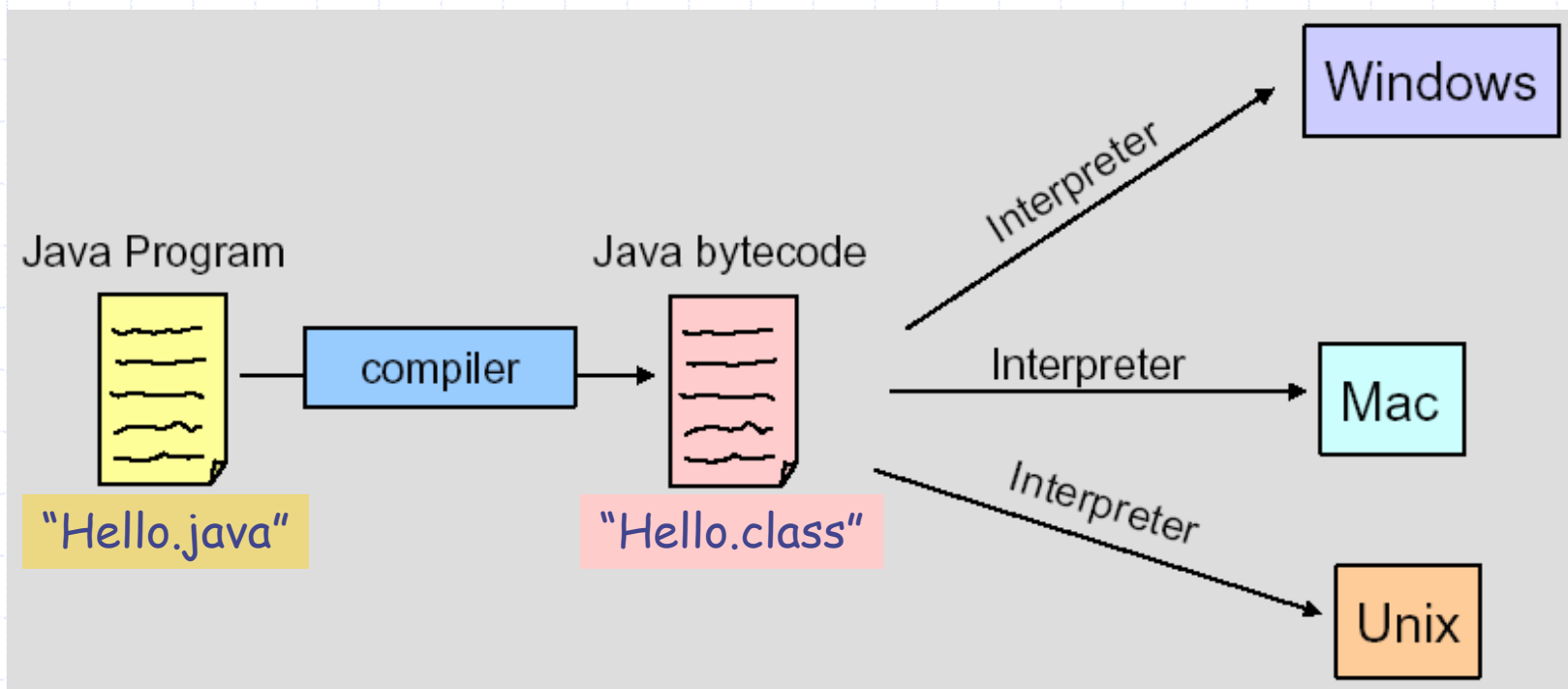

Multipurpose Java Compiling

Java Program

```
class HelloWorldApp {  
    public static void main(String[] args) {  
        System.out.println("Hello World!");  
    }  
}
```

HelloWorldApp.java

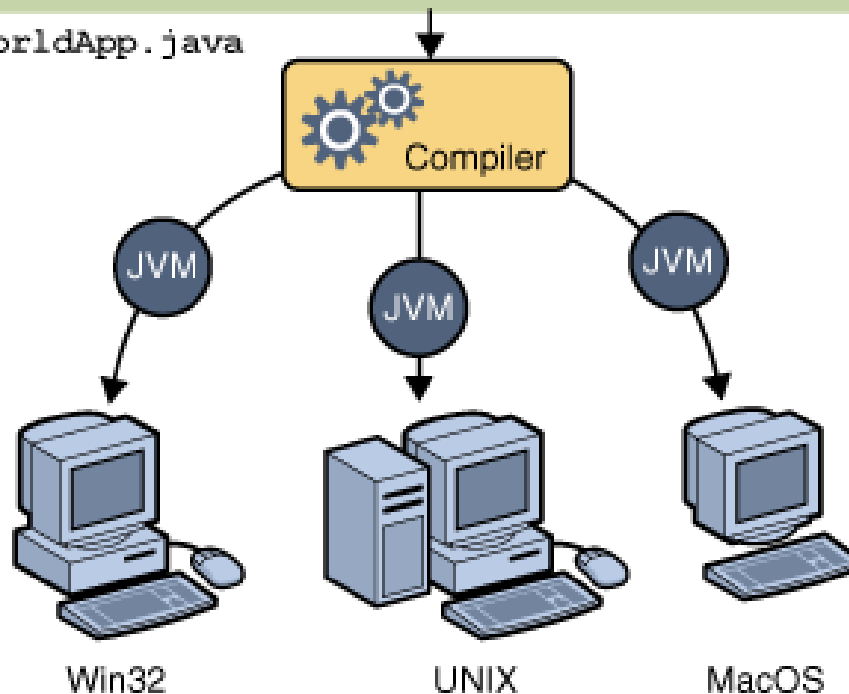

Running The Program

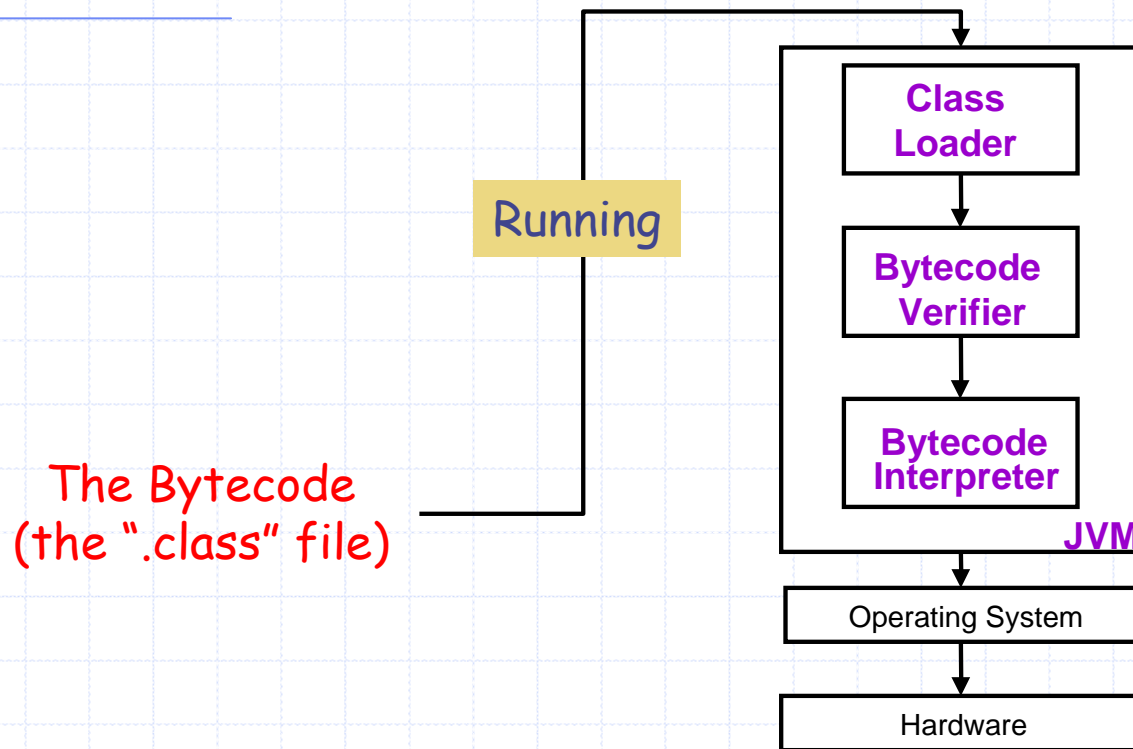

The Java Virtual Machine Components

- **The Class Loader**
 - stores bytecodes in memory
- **Bytecode Verifier**
 - ensures bytecodes do not violate security requirements
- **Bytecode Interpreter**
 - translates bytecodes into machine language

The Java Virtual Machine

- The **class Loader**, the **Bytecode Verifier** and **Interpreter** constitute the Java Virtual Machine (**JVM**).
- JVM is platform specific.
- The interpreter translates the bytecodes into specific machine commands.

Testing and Debugging the Program

- **Testing**

- Be sure that the output of the program conforms with the input.
- There are two types of errors:
 - **Logical Errors:** The program run but provides wrong output.
 - **Runtime errors:** The program stop running suddenly when asking the OS executing a non accepted statement (divide by zero, etc).

- **Debugging**

- Find, Understand and correct the error

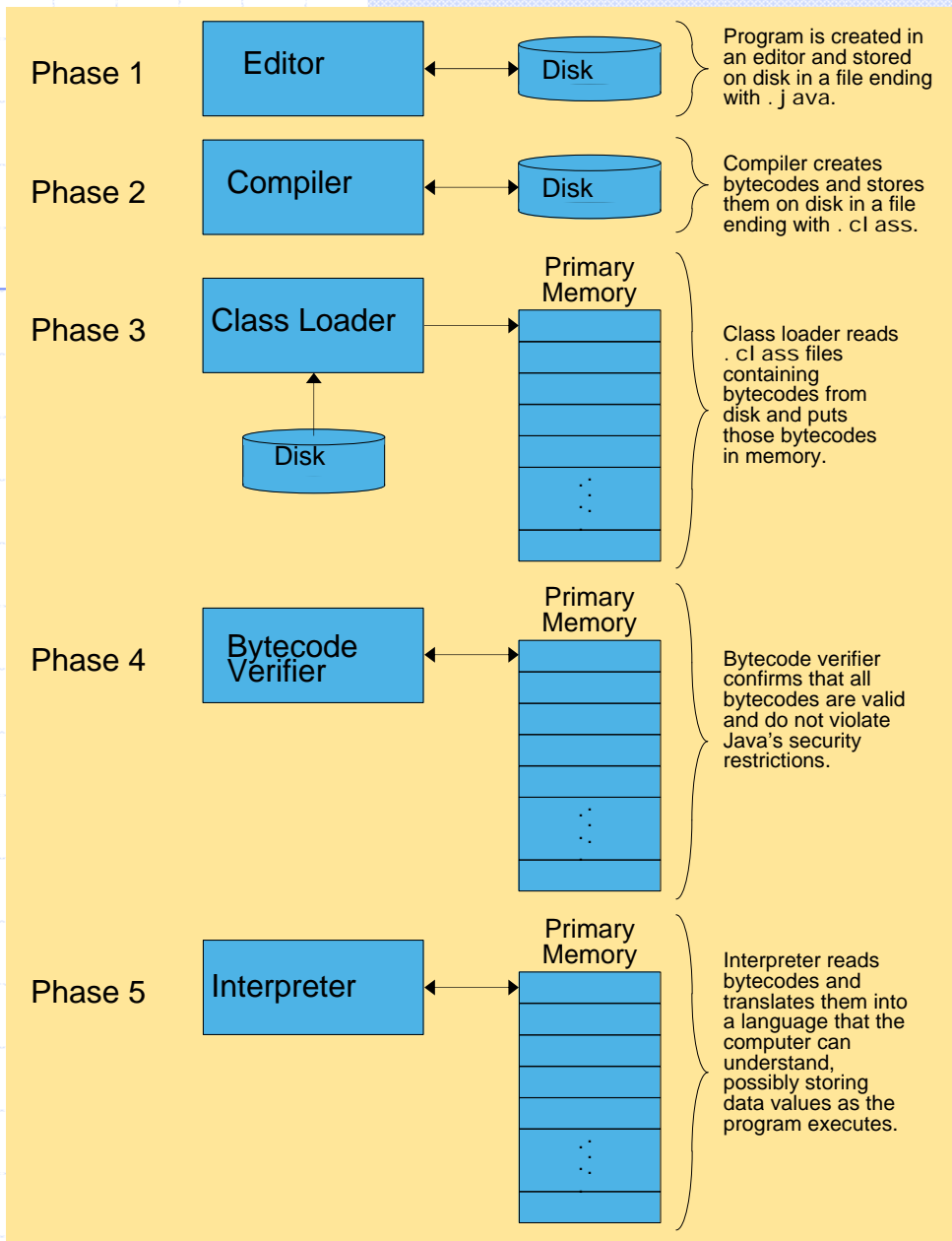

Some Characteristics of Java

- Object-Oriented
 - Combines data and behavior into one unit → **objects**
 - Provides Data abstraction and encapsulation
 - Decompose program into objects.
 - Programs are collections of interacting and cooperating objects.
- Platform-independent
 - Portable
 - Architecture neutral
 - "Write-once, run-anywhere"
- Secure
 - The bytecode verifier of the JVM :
 - checks untrusted bytecode
 - controls the permissions for high level actions.