

# Newton's Rings

## 1 Objective

Calculating the wavelength of the D-line in a sodium lamp.

## 2 Prelab Questions

1. Give a general explanation of the phenomenon of light interference: constructive interference, destructive interference and what is meant by bright/dark fringes.
2. Briefly explain the phenomenon of thin-film interference.

## 3 Principles

Light from a light source with a discrete spectrum is directed towards a reflective plate. The light is then passed through a lens and allowed to interfere.

## 4 Apparatus

- Travelling microscope.
- Sodium lamp.
- Plano-convex lens [L] with a focal length  $f = 10\text{cm}$ .

- Planar plate [P].
- Sheet of glass [G] placed at an angle so that it reflects light towards the lens [L] and plate [P].

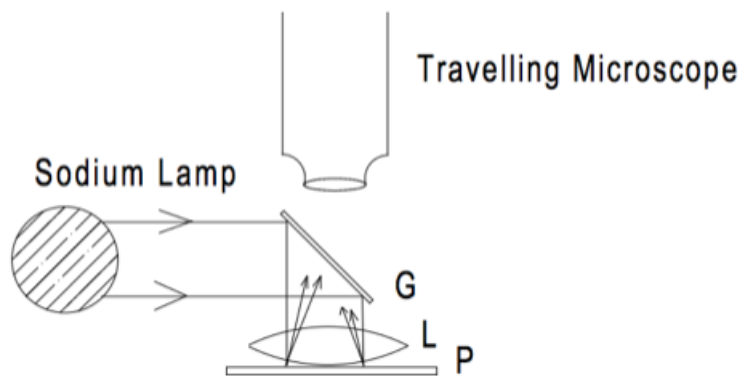

## 5 Precautions

1. Optical systems are sensitive and are often fine-tuned. Be very careful with the equipment, as a slight nudge might damage the equipment.
2. The lens, glass sheet and the planar plate are delicate components, thoroughly clean them and make sure not to scratch their surface.
3. Stray light can obscure the images seen through the microscope. Perform the experiment in pitch-black darkness.

## 6 Experimental Steps

1. Switch on the lamp and wait for a while until the light it emits regulates and turns yellow.
2. Using your naked eye, notice the formation of concentric rings in the space between the lens and the planar plate.

3. Place the travelling microscope directly above the glass sheet. Look through the microscope and adjust its position by moving it upwards or downwards until the rings come into focus. The rings are referred to as fringes and they form due to the interference of light.
4. Search for the centre of the rings by moving the microscope rightwards or leftwards. Upon finding the centre, place the crosshairs directly in the middle
5. Notice that the crosshairs divide the concentric circles in half. There is a right-hand side and a left-hand side.
6. Move the microscope towards the right-hand side, and align the vertical crosshair with the outer edge of the tenth fringe (tenth circle). Record the reading of the microscope  $d_r$  and the fringe number  $n$ .
7. Now move the microscope towards the left, and align it with the outer edge of the ninth fringe (ninth circle). Notice that you are still in the right-hand side.
8. Repeat steps [6 and 7] for each fringe, crossing the centre and moving on to the left-hand side.
9. Once you crossed towards the left-hand side, start recording  $d_l$  as well as the fringe number  $n$ , until you reach the outer edge of the tenth fringe on the left-hand side.

## 7 Evaluation

1. Calculate the diameter of the fringes using:

$$D = |d_r - d_l| \quad (1)$$

And then square it to obtain  $D^2$ .

2. Plot a graph between the fringe number  $n$  and the square of the diameter  $D^2$ .
3. Using the slope of the graph, calculate the wavelength of the D-line, given:

$$\lambda = \frac{1}{4R} \times \frac{D^2}{n} \quad (2)$$

Where  $R = 50\text{cm}$ .

## 8 Postlab Questions

1. Explain the reason behind the concentricity of the interference pattern you observed in the experiment.
2. Colour shifting ink used in modern banknotes as a measure against counterfeit notes displays two distinct colours depending on the angle of viewing. Using the concept of thin-film interference, can you explain how this effect is achieved?