

104 PHYS

Ch. 33

Alternating Current Circuits

Dr. Ayman Alismail ©



Contents



- sec. 33.01 AC Sources
- sec. 33.02 Resistors in an AC Circuit
- sec. 33.03 Inductors in an AC Circuit
- sec. 33.04 Capacitors in an AC Circuit
- sec. 33.05 The RLC Series Circuit
- sec. 33.06 Power in an AC Circuit
- sec. 33.07 Resonance in a Series RLC Circuit

- An AC circuit consists of circuit elements and a power source that provides an alternating voltage Δv . This time-varying voltage is described by:

$$\Delta v = \Delta V_{max} \sin \omega t$$

- Where ΔV_{max} is the maximum output voltage of the AC source, or the **voltage amplitude**.
- The angular frequency of the AC voltage is:

$$\omega = 2\pi f = \frac{2\pi}{T}$$

- Where f is the frequency of the source and T is the period.
- Because the output voltage of an AC source varies sinusoidally with time, the voltage is positive during one half of the cycle and negative during the other half.
- Likewise, the current in any circuit driven by an AC source is an alternating current that also varies sinusoidally with time.

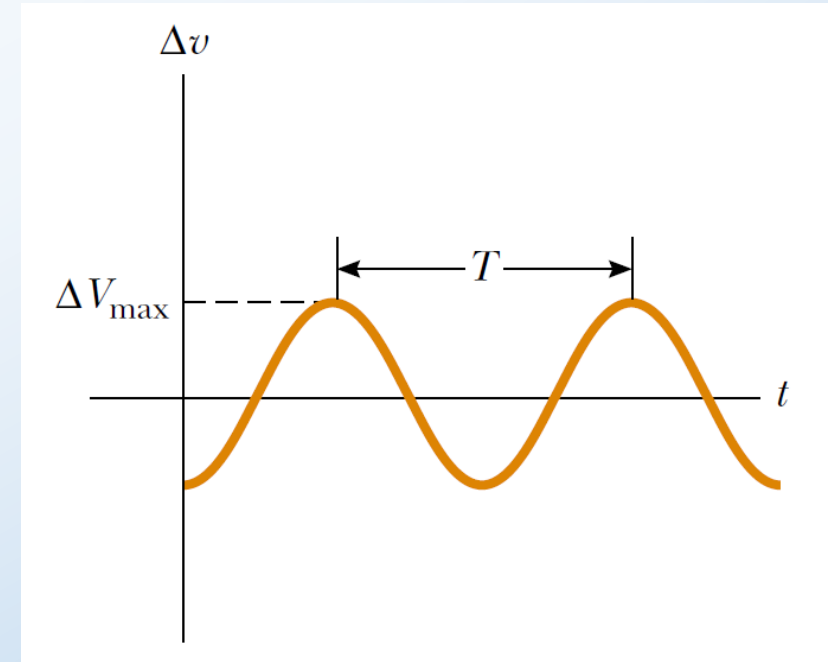

The voltage supplied by an AC source is sinusoidal with a period T .

- Consider a simple AC circuit consisting of a resistor and an AC source .
- At any instant, the algebraic sum of the voltages around a closed loop in a circuit must be zero (Kirchhoff's loop rule).
- Therefore, $\Delta v + \Delta v_R = 0$, so that the magnitude of the source voltage equals the magnitude of the voltage across the resistor:

$$\Delta v = \Delta v_R = \Delta V_{max} \sin \omega t$$

- Where Δv_R is the **instantaneous voltage across the resistor**.
- Therefore, the instantaneous current in the resistor is:

$$i_R = \frac{\Delta v_R}{R} = \frac{\Delta V_{max}}{R} \sin \omega t = I_{max} \sin \omega t$$

- Where I_{max} is the maximum current:

$$I_{max} = \frac{\Delta V_{max}}{R}$$

- The instantaneous voltage across the resistor is:

$$\Delta v_R = I_{max} R \sin \omega t$$

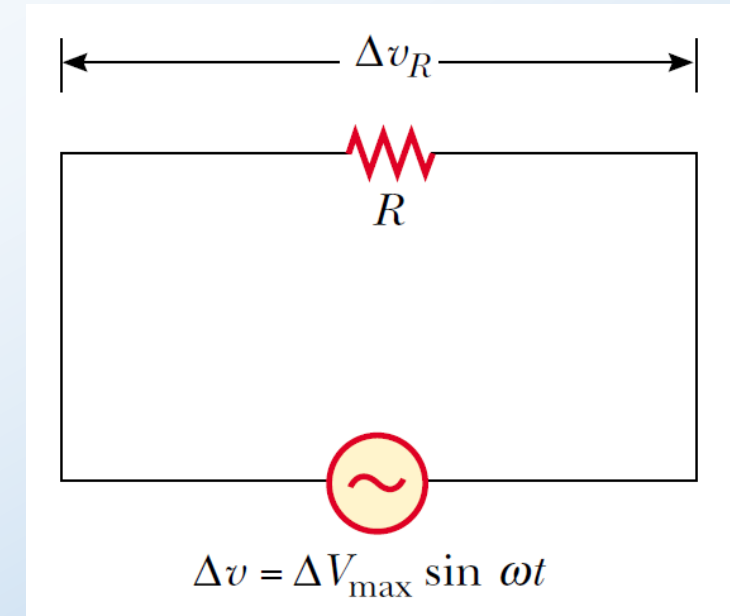

A circuit consisting of a resistor of resistance R connected to an AC source, designated by the symbol .

- A plot of voltage and current versus time for this circuit is shown in Fig. (a):
 - At point a , the current has a maximum value in one direction, arbitrarily called the positive direction.
 - Between points a and b , the current is decreasing in magnitude but is still in the positive direction.
 - At b , the current is momentarily zero; it then begins to increase in the negative direction between points b and c .
 - At c , the current has reached its maximum value in the negative direction.
- The current and voltage are in step with each other because they vary identically with time.
- Because i_R and Δv_R both vary as $\sin \omega t$ and reach their maximum values at the same time, as shown in Fig. (a), they are said to be **in phase**.
- Thus, **for a sinusoidal applied voltage, the current in a resistor is always in phase with the voltage across the resistor.**
- For resistors in AC circuits, there are no new concepts to learn. Resistors behave essentially the same way in both DC and AC circuits.

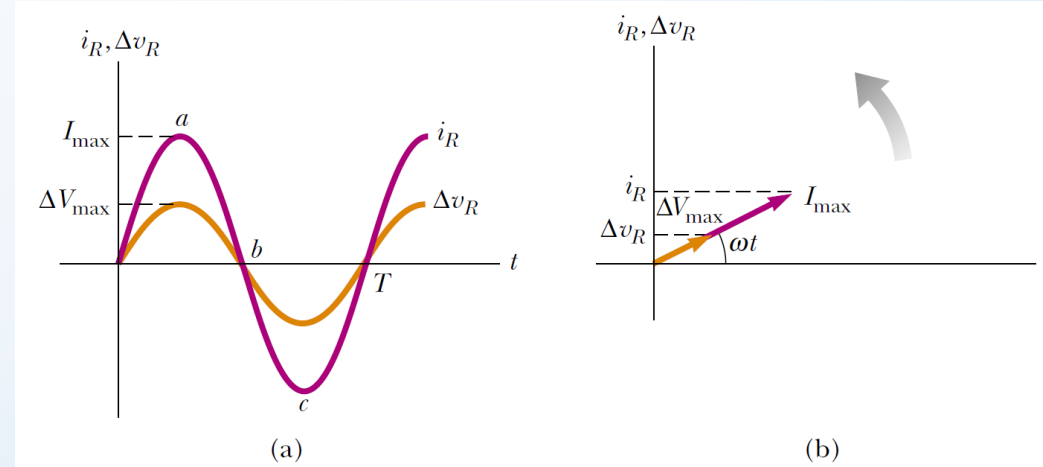

(a) Plots of the instantaneous current i_R and instantaneous voltage Δv_R across a resistor as functions of time. The current is in phase with the voltage, which means that the current is zero when the voltage is zero, maximum when the voltage is maximum, and minimum when the voltage is minimum. At time $t = T$, one cycle of the time-varying voltage and current has been completed. (b) Phasor diagram for the resistive circuit showing that the current is in phase with the voltage.

- To simplify our analysis of circuits containing two or more elements, we use graphical constructions called phasor diagrams:
 - A **phasor** is a vector whose length is proportional to the maximum value of the variable it represents (ΔV_{max} for voltage and I_{max} for current in the present discussion) and which rotates counterclockwise at an angular speed equal to the angular frequency associated with the variable.
 - The projection of the phasor onto the vertical axis represents the instantaneous value of the quantity it represents.
- The projections of the phasor arrows onto the vertical axis are determined by a sine function of the angle of the phasor with respect to the horizontal axis.
- For example, the projection of the current phasor in Fig. (b) is $I_{max} \sin \omega t$.
- Thus, we can use the projections of phasors to represent current values that vary sinusoidally in time.
- We can do the same with time-varying voltages.
- The advantage of this approach is that the phase relationships among currents and voltages can be represented as vector additions of phasors.

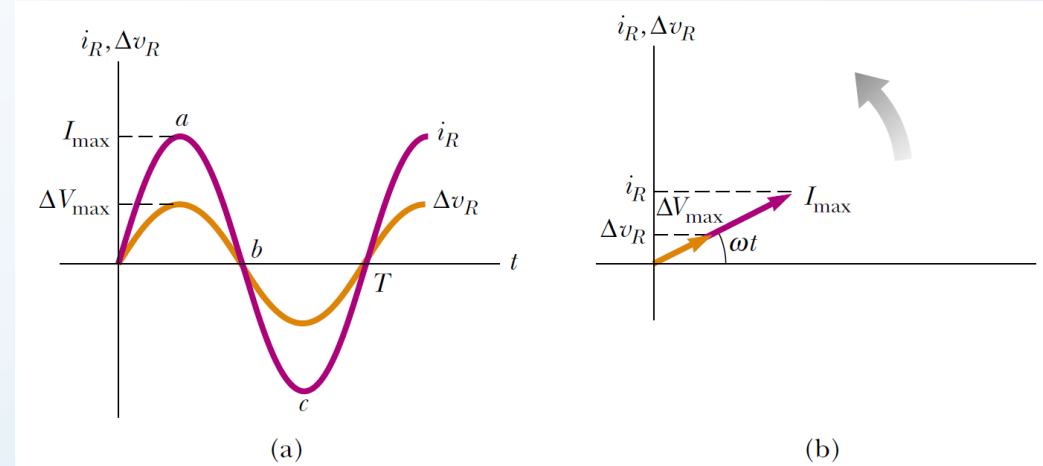

(a) Plots of the instantaneous current i_R and instantaneous voltage Δv_R across a resistor as functions of time. The current is in phase with the voltage, which means that the current is zero when the voltage is zero, maximum when the voltage is maximum, and minimum when the voltage is minimum. At time $t = T$, one cycle of the time-varying voltage and current has been completed. (b) Phasor diagram for the resistive circuit showing that the current is in phase with the voltage.

Quick Quiz 33.1 Consider the voltage phasor in the following figure, shown at three instants of time. Choose the part of the figure that represents the instant of time at which the instantaneous value of the voltage has the largest magnitude.

Answer (a). The phasor in part (a) has the largest projection onto the vertical axis.

Quick Quiz 33.2 For the voltage phasor in the following figure, choose the part of the figure that represents the instant of time at which the instantaneous value of the voltage has the smallest magnitude.

Answer (b). The phasor in part (b) has the smallest-magnitude projection onto the vertical axis.

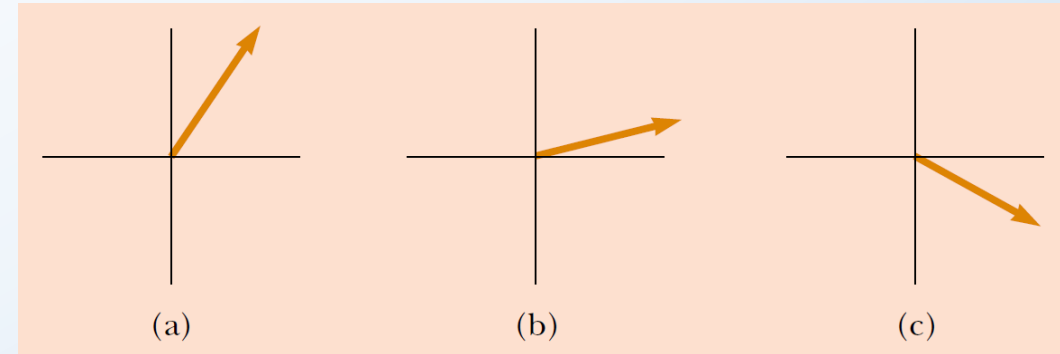

A voltage phasor is shown at three instants

- For the simple resistive circuit, **the average value of the current over one cycle is zero.**
- The collisions between electrons and the fixed atoms of the resistor result in an increase in the resistor's temperature. Although this temperature increase depends on the magnitude of the current, it is independent of the direction of the current.
- We can understand this by recalling that the rate at which energy is delivered to a resistor is the power $\mathcal{P} = i^2R$, where i is the instantaneous current in the resistor.
- Because this rate is proportional to the square of the current, it makes no difference whether the current is direct or alternating—that is, whether the sign associated with the current is positive or negative.
- However, the temperature increase produced by an alternating current having a maximum value I_{max} is not the same as that produced by a direct current equal to I_{max} .
- This is because the alternating current is at this maximum value for only an instant during each cycle (Fig. (a)).

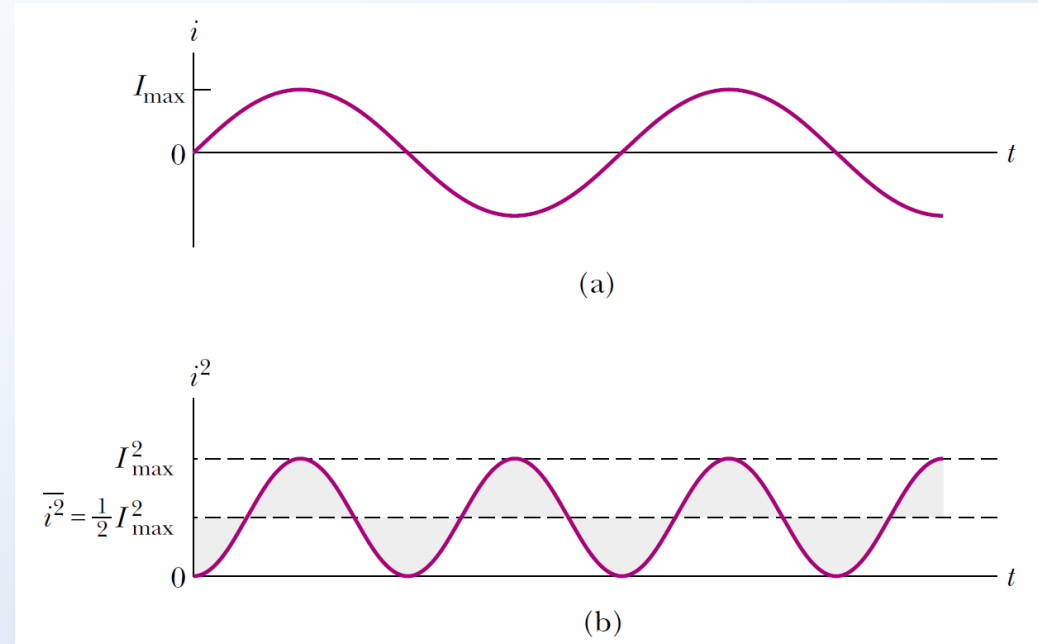

(a) Graph of the current in a resistor as a function of time. (b) Graph of the current squared in a resistor as a function of time. Notice that the gray shaded regions under the curve and above the dashed line for $I_{max}^2/2$ have the same area as the gray shaded regions above the curve and below the dashed line for $I_{max}^2/2$. Thus, the average value of i^2 is $I_{max}^2/2$.

- In an AC circuit, the average value of current is referred to as the **rms current**.
- The notation rms stands for root-mean square, which in this case means the square root of the mean (average) value of the square of the current: $I_{rms} = \sqrt{\overline{i^2}}$.
- Because i^2 varies as $\sin^2 \omega t$ and because $\overline{i^2}$ is $\frac{1}{2}I_{max}^2$ (see Fig. (b)), the rms current is:

$$I_{rms} = \frac{I_{max}}{\sqrt{2}} = 0.707I_{max}$$

- Thus, the average power delivered to a resistor that carries an alternating current is:

$$\mathcal{P}_{av} = I_{rms}^2 R = I_{rms}(\Delta V_{rms}) = \frac{(\Delta V_{rms})^2}{R}$$

- Alternating voltage is also best discussed in terms of rms voltage, and the relationship is identical to that for current:

$$\Delta V_{rms} = \frac{\Delta V_{max}}{\sqrt{2}} = 0.707\Delta V_{max}$$

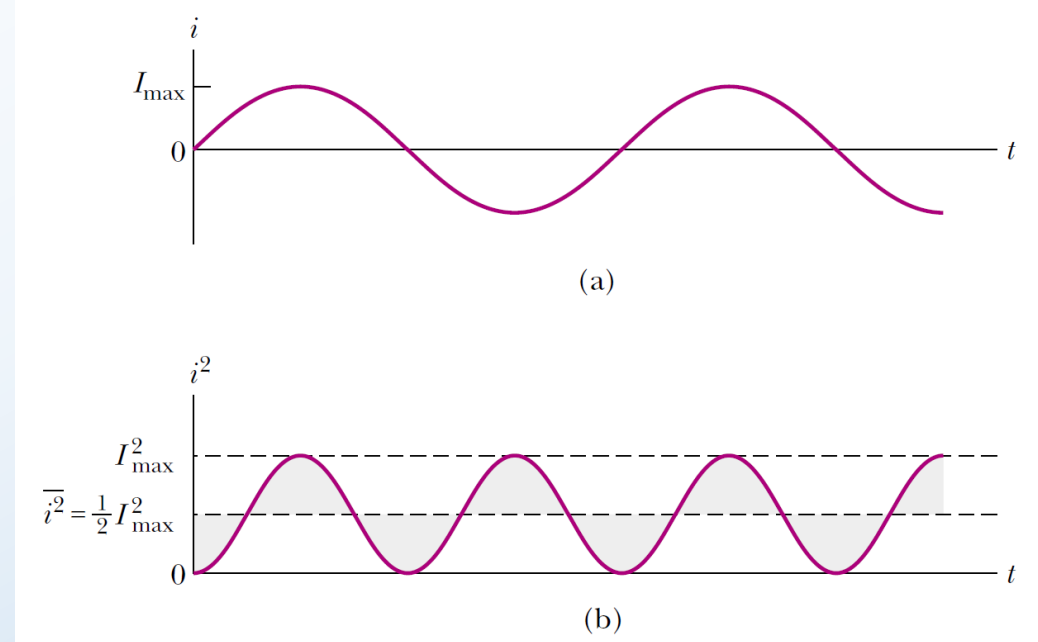

(a) Graph of the current in a resistor as a function of time. (b) Graph of the current squared in a resistor as a function of time. Notice that the gray shaded regions under the curve and above the dashed line for $I_{max}^2/2$ have the same area as the gray shaded regions above the curve and below the dashed line for $I_{max}^2/2$. Thus, the average value of i^2 is $I_{max}^2/2$.



Example 33.01

The voltage output of an AC source is given by the expression $\Delta v = (200 \text{ V}) \sin \omega t$. Find the rms current in the circuit when this source is connected to a $100 - \Omega$ resistor.

Comparing this expression for voltage output with the general form $\Delta v = \Delta V_{max} \sin \omega t$, we see that $\Delta V_{max} = 200 \text{ V}$. Thus, the rms voltage is:

$$\Delta V_{rms} = \frac{\Delta V_{max}}{\sqrt{2}} = \frac{200}{\sqrt{2}} = 141 \text{ V}$$

Therefore,

$$I_{rms} = \frac{\Delta V_{rms}}{R} = \frac{141}{100} = 1.41 \text{ A}$$



Problem 33.02

Additional problem

(a) What is the resistance of a lightbulb that uses an average power of 75.0 W when connected to a 60.0 – Hz power source having a maximum voltage of 170 V? (b) What If? What is the resistance of a 100 – W bulb?

$$(a) \Delta V_{rms} = \frac{\Delta V_{max}}{\sqrt{2}} = \frac{170}{\sqrt{2}} = 120 \text{ V}$$

$$\mathcal{P}_{av} = \frac{(\Delta V_{rms})^2}{R}$$

$$R = \frac{(\Delta V_{rms})^2}{\mathcal{P}_{av}} = \frac{(120)^2}{75.0} = 193 \Omega$$

$$(b) R = \frac{(\Delta V_{rms})^2}{\mathcal{P}_{av}} = \frac{(120)^2}{100} = 144 \Omega$$

Problem 33.03

Additional problem

An AC power supply produces a maximum voltage $\Delta V_{max} = 100 \text{ V}$. This power supply is connected to a $24.0 \text{ } \Omega$ resistor, and the current and resistor voltage are measured with an ideal AC ammeter and voltmeter, as shown in the following figure. What does each meter read? Note that an ideal ammeter has zero resistance and that an ideal voltmeter has infinite resistance.

Each meter reads the rms value.

$$\Delta V_{rms} = \frac{\Delta V_{max}}{\sqrt{2}} = \frac{100}{\sqrt{2}} = 70.7 \text{ V}$$

$$I_{rms} = \frac{\Delta V_{rms}}{R} = \frac{70.7}{24.0} = 2.95 \text{ A}$$

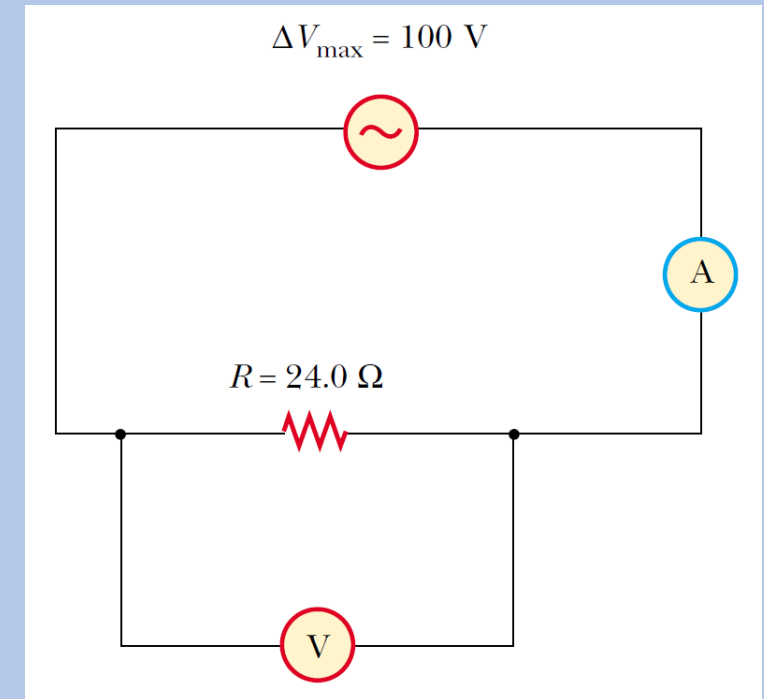

Problem 33.06

The following figure shows three lamps connected to a 120 – V AC (rms) household supply voltage. Lamps 1 and 2 have 150 – W bulbs; lamp 3 has a 100 – W bulb. Find the rms current and resistance of each bulb.

$$\Delta V_{rms} = \Delta V_{rms1} = \Delta V_{rms2} = \Delta V_{rms3}$$

$$\mathcal{P}_{av} = I_{rms}(\Delta V_{rms}), \quad I_{rms} = \frac{\Delta V_{rms}}{R}$$

$$I_{rms1} = \frac{\mathcal{P}_1}{\Delta V_{rms}} = \frac{150}{120} = 1.25 \text{ A},$$

$$R_1 = \frac{\Delta V_{rms}}{I_{rms1}} = \frac{120}{1.25} = 96.0 \ \Omega$$

$$I_{rms2} = \frac{\mathcal{P}_2}{\Delta V_{rms}} = \frac{150}{120} = 1.25 \text{ A},$$

$$R_2 = \frac{\Delta V_{rms}}{I_{rms2}} = \frac{120}{1.25} = 96.0 \ \Omega$$

$$I_{rms3} = \frac{\mathcal{P}_3}{\Delta V_{rms}} = \frac{100}{120} = 0.833 \text{ A},$$

$$R_3 = \frac{\Delta V_{rms}}{I_{rms3}} = \frac{120}{0.833} = 144 \ \Omega$$

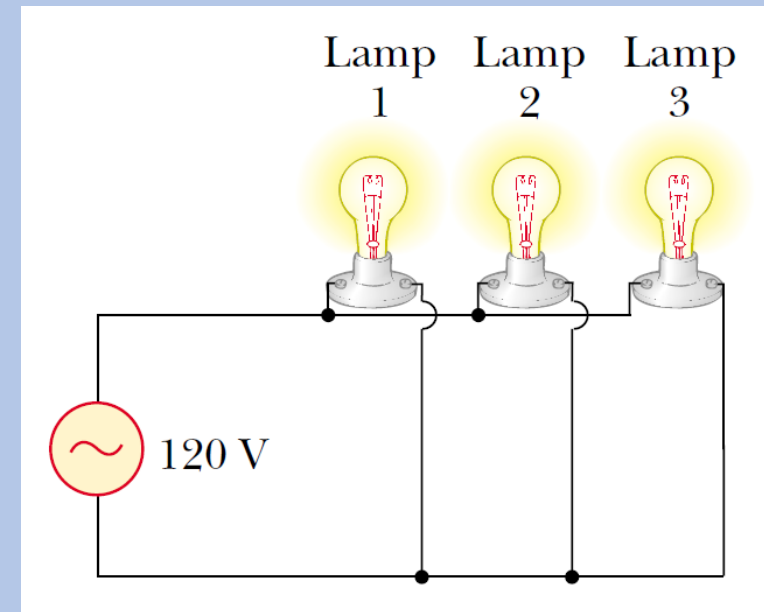

- Consider an AC circuit consisting only of an inductor connected to the terminals of an AC source.
- If $\Delta v_L = \mathcal{E}_L = -L(di/dt)$ is the self-induced instantaneous voltage across the inductor, then Kirchoff's loop rule applied to this circuit gives $\Delta v + \Delta v_L = 0$, or:

$$\Delta v - L \frac{di}{dt} = 0$$

- When we substitute $\Delta V_{max} \sin \omega t$ for Δv and rearrange, we obtain:

$$\Delta v = L \frac{di}{dt} = \Delta V_{max} \sin \omega t$$

- Solving this equation for di , we find that:

$$di = \frac{\Delta V_{max}}{L} \sin \omega t dt$$

- Integrating this expression gives the instantaneous current i_L in the inductor as a function of time:

$$i_L = \frac{\Delta V_{max}}{L} \int \sin \omega t dt = -\frac{\Delta V_{max}}{\omega L} \cos \omega t$$

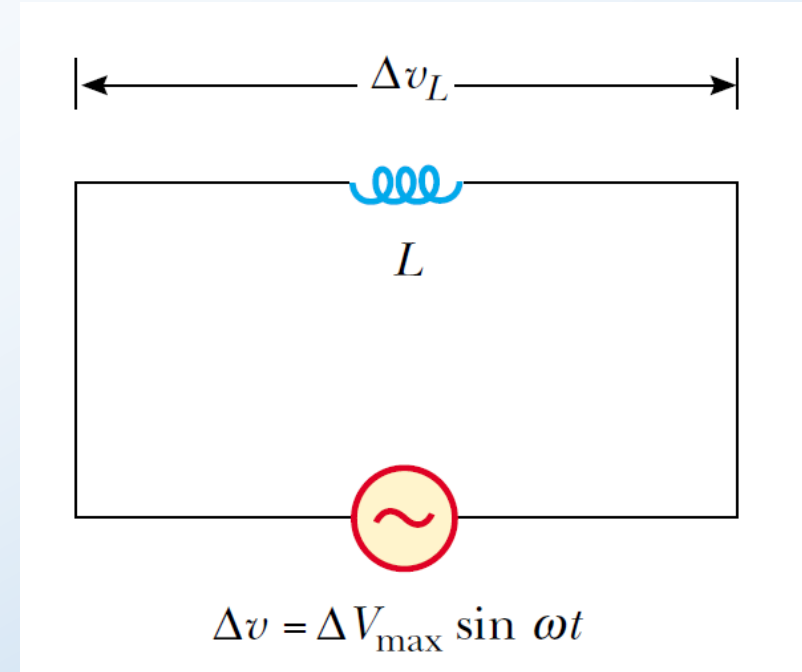

A circuit consisting of an inductor of inductance L connected to an AC source.

- When we use the trigonometric identity $\cos \omega t = -\sin(\omega t - \pi/2)$, we can express i_L as:

$$i_L = \frac{\Delta V_{max}}{\omega L} \sin\left(\omega t - \frac{\pi}{2}\right)$$

- Comparing the result of i_L with Δv , we see that the instantaneous current i_L in the inductor and the instantaneous voltage Δv_L across the inductor are out of phase by $(\pi/2)$ rad = 90° (Fig. (a)).
- In general, inductors in an AC circuit produce a current that is out of phase with the AC voltage.
- For example, when the current i_L in the inductor is a maximum (point b in Fig. (a)), the voltage across the inductor is zero (point d).
- Note that the voltage reaches its maximum value one quarter of a period before the current reaches its maximum value. Thus, we see that:

for a sinusoidal applied voltage, the current in an inductor always lags behind the voltage across the inductor by 90° (one-quarter cycle in time).

- From the phasor diagram (Fig. (b)), the phasors are at 90° to one another, representing the 90° phase difference between current and voltage.

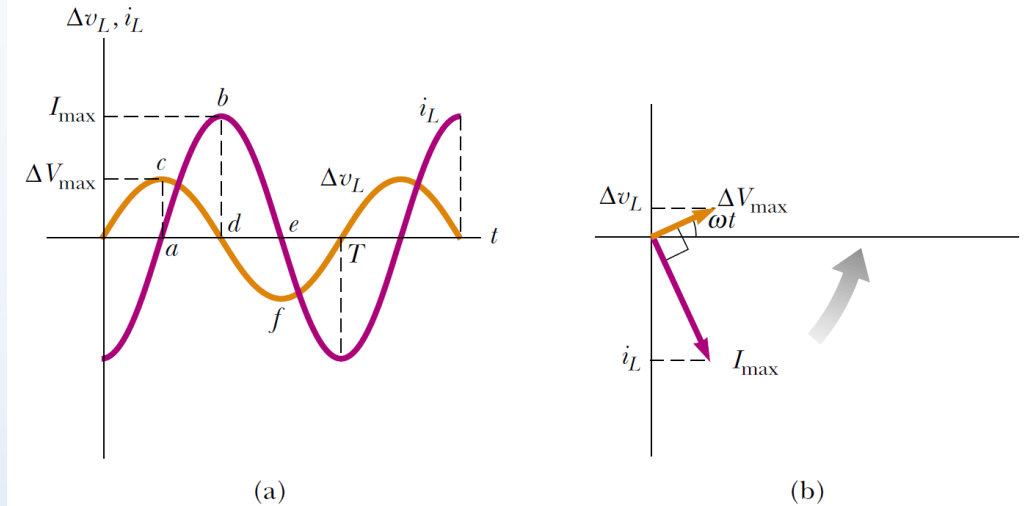

(a) Plots of the instantaneous current i_L and instantaneous voltage Δv_L across an inductor as functions of time. The current lags behind the voltage by 90° . (b) Phasor diagram for the inductive circuit, showing that the current lags behind the voltage by 90° .

- The current in an inductive circuit reaches its maximum value when $\cos \omega t = -1$:

$$I_{max} = \frac{\Delta V_{max}}{\omega L}$$

- In fact, ωL must behave in a manner similar to resistance, in the sense that it represents opposition to the flow of charge. Therefore, ωL must have units of ohms.
- Notice that because ωL depends on the applied frequency ω , the inductor reacts differently, in terms of offering resistance to current, for different frequencies.
- For this reason, we define ωL as the **inductive reactance**:

$$X_L \equiv \omega L$$

- And we can write I_{max} as:

$$I_{max} = \frac{\Delta V_{max}}{X_L}$$

- For the expression of the rms current in an inductor, I_{max} is replaced by I_{rms} and ΔV_{max} is replaced by ΔV_{rms} .
- For a given applied voltage, the inductive reactance increases as ω increases.
- The instantaneous voltage across the inductor is:

$$\Delta v_L = -L \frac{di}{dt} = -\Delta V_{max} \sin \omega t = -I_{max} X_L \sin \omega t$$

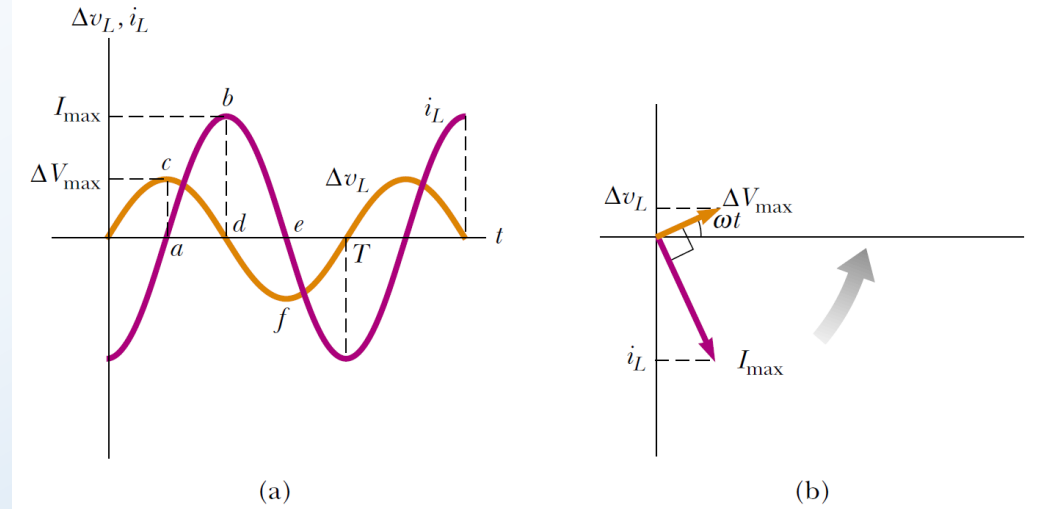

(a) Plots of the instantaneous current i_L and instantaneous voltage Δv_L across an inductor as functions of time. The current lags behind the voltage by 90° . (b) Phasor diagram for the inductive circuit, showing that the current lags behind the voltage by 90° .

Quick Quiz 33.4 Consider the AC circuit in the following figure. The frequency of the AC source is adjusted while its voltage amplitude is held constant. The lightbulb will glow the brightest at:

- (a) high frequencies.
- (b) low frequencies.
- (c) The brightness will be the same at all frequencies.

Answer (b). For low frequencies, the reactance of the inductor is small so that the current is large. Most of the voltage from the source is across the bulb, so the power delivered to it is large.

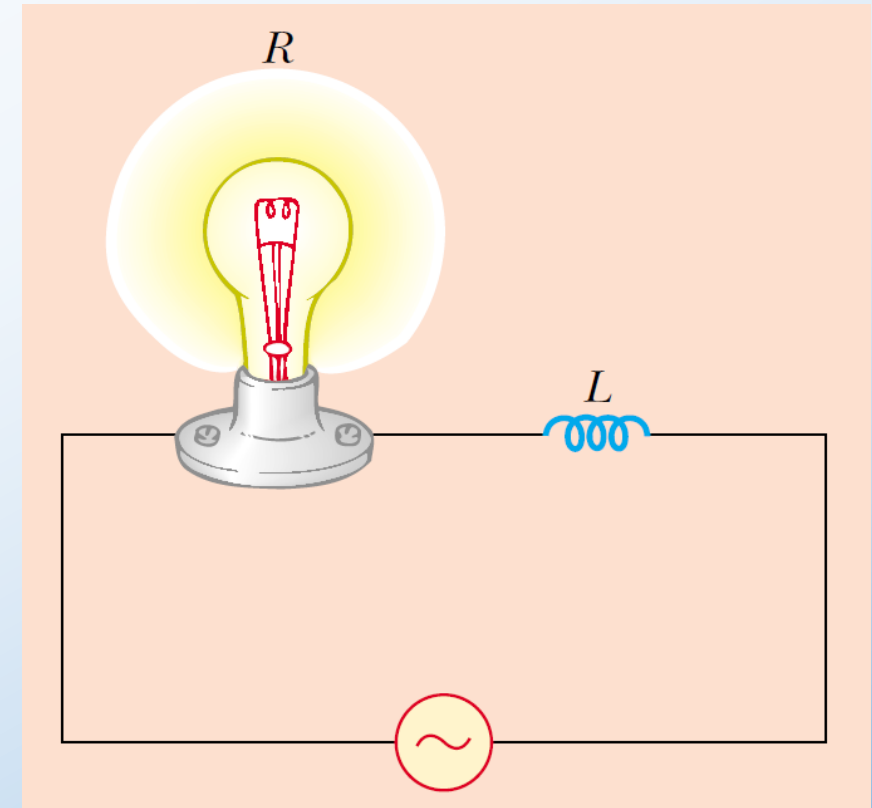

At what frequencies will the bulb glow the brightest?

Example 33.02

In a purely inductive AC circuit (see the following figure), $L = 25.0$ mH and the rms voltage is 150 V. Calculate the inductive reactance and rms current in the circuit if the frequency is 60.0 Hz.

$$X_L = \omega L = 2\pi fL = 2 \times \pi \times 60.0 \times 25.0 \times 10^{-3} = 9.42 \Omega$$

The rms current is:

$$I_{rms} = \frac{\Delta V_{L,rms}}{X_L} = \frac{150}{9.42} = 15.9 \text{ A}$$

What If? What if the frequency increases to 6.00 kHz? What happens to the rms current in the circuit?

Answer If the frequency increases, the inductive reactance increases because the current is changing at a higher rate. The increase in inductive reactance results in a lower current.

Let us calculate the new inductive reactance:

$$X_L = \omega L = 2\pi fL = 2 \times \pi \times 6.00 \times 10^3 \times 25.0 \times 10^{-3} = 942 \Omega$$

The new rms current is:

$$I_{rms} = \frac{\Delta V_{L,rms}}{X_L} = \frac{150}{942} = 0.159 \text{ A}$$

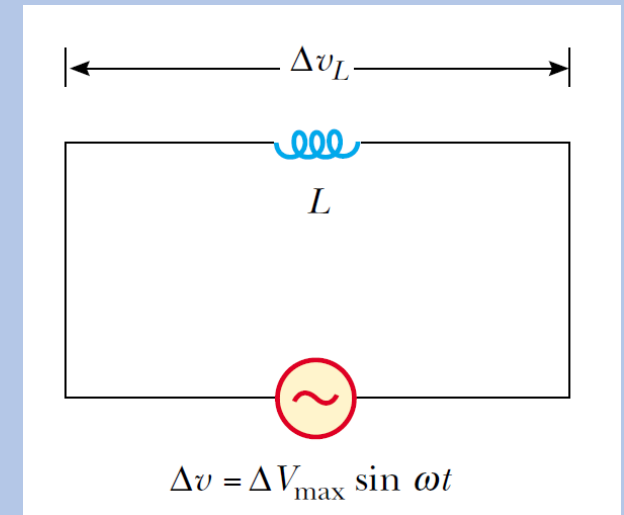



Problem 33.10

An inductor has a $54.0\text{ }\Omega$ reactance at 60.0 Hz . What is the maximum current if this inductor is connected to a 50.0 Hz source that produces a 100 V rms voltage?

$$X_L = \omega L = 2\pi fL$$

At 60.0 Hz :

$$L = \frac{X_L|_{60.0\text{ Hz}}}{2\pi f} = \frac{54.0}{2 \times \pi \times 60.0} = 0.143\text{ H}$$

At 50.0 Hz :

$$X_L = \omega L = 2\pi fL = 2 \times \pi \times 50.0 \times 0.143 = 45.0\text{ }\Omega$$

$$I_{max} = \frac{\Delta V_{max}}{X_L} = \frac{\sqrt{2}(\Delta V_{rms})}{X_L} = \frac{\sqrt{2} \times 100}{45.0} = 3.14\text{ A}$$

- Consider an AC circuit consisting of a capacitor connected across the terminals of an AC source.
- Kirchhoff's loop rule applied to this circuit gives $\Delta v + \Delta v_C = 0$, so that the magnitude of the source voltage is equal to the magnitude of the voltage across the capacitor:

$$\Delta v = \Delta v_C = \Delta V_{max} \sin \omega t$$

- Where Δv_C is the instantaneous voltage across the capacitor.
- Using the definition of capacitance that $C = q/\Delta v_C$ gives:

$$q = C \Delta V_{max} \sin \omega t$$

- Where q is the instantaneous charge on the capacitor.
- Because $i = dq/dt$, differentiating q with respect to t gives the instantaneous current in the circuit:

$$i_C = \frac{dq}{dt} = \omega C \Delta V_{max} \cos \omega t$$

- When we use the trigonometric identity $\cos \omega t = \sin(\omega t + \pi/2)$, we can express i_C as:

$$i_C = \omega C \Delta V_{max} \sin\left(\omega t + \frac{\pi}{2}\right)$$

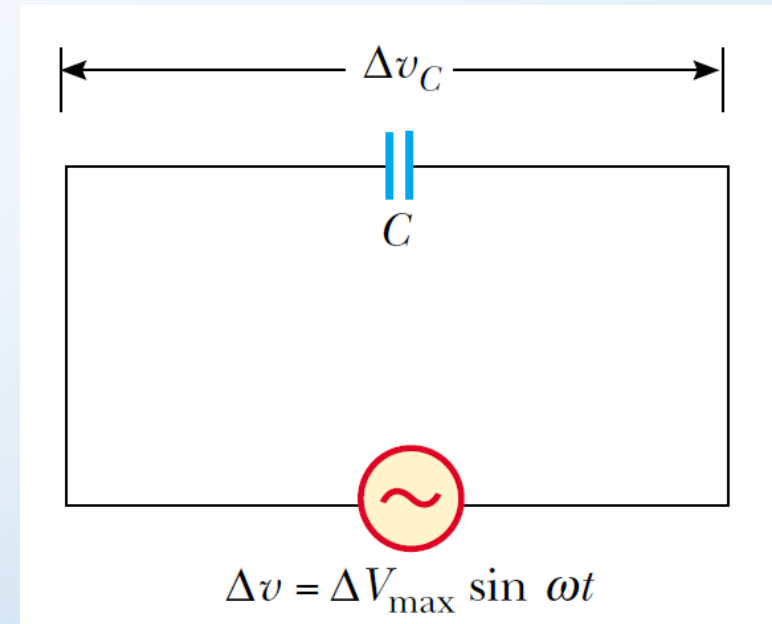

A circuit consisting of a capacitor of capacitance C connected to an AC source.

- Comparing the expressions of Δv_C and i_C , we see that the current is $(\pi/2)$ rad = 90° out of phase with the voltage across the capacitor.
- A plot of current and voltage versus time (Fig. (a)) shows that the current reaches its maximum value one quarter of a cycle sooner than the voltage reaches its maximum value.
- Looking more closely, consider a point such as b where the current is zero.
- This occurs when the capacitor has just reached its maximum charge, so the voltage across the capacitor is a maximum (point d).
- At points such as a and e , the current is a maximum, which occurs at those instants at which the charge on the capacitor has just gone to zero and it begins to charge up with the opposite polarity.
- Because the charge is zero, the voltage across the capacitor is zero (points c and f).
- Thus, the current and voltage are out of phase.
- As with inductors, we can represent the current and voltage for a capacitor on a phasor diagram.
- The phasor diagram in Fig. (b) shows that:

for a sinusoidally applied voltage, the current always leads the voltage across a capacitor by 90° .

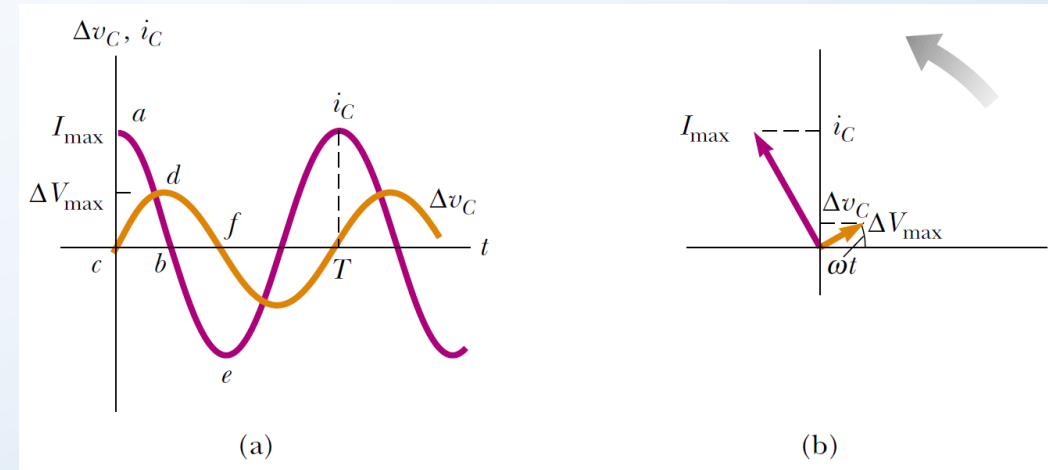

(a) Plots of the instantaneous current i_C and instantaneous voltage Δv_C across a capacitor as functions of time. The voltage lags behind the current by 90° . (b) Phasor diagram for the capacitive circuit, showing that the current leads the voltage by 90° .

- The current in the circuit reaches its maximum value when $\cos \omega t = 1$:

$$I_{max} = \omega C \Delta V_{max} = \frac{\Delta V_{max}}{(1/\omega C)}$$

- As in the case with inductors, the denominator must play the role of resistance, with units of ohms.
- We give the combination $1/\omega C$ the symbol X_C , and because this function varies with frequency, we define it as the **capacitive reactance**:

$$X_C \equiv \frac{1}{\omega C}$$

- And we can write I_{max} as:

$$I_{max} = \frac{\Delta V_{max}}{X_C}$$

- For the expression of the rms current in a capacitor, I_{max} is replaced by I_{rms} and ΔV_{max} is replaced by ΔV_{rms} .
- The instantaneous voltage across the capacitor is:

$$\Delta v_C = \Delta V_{max} \sin \omega t = I_{max} X_C \sin \omega t$$

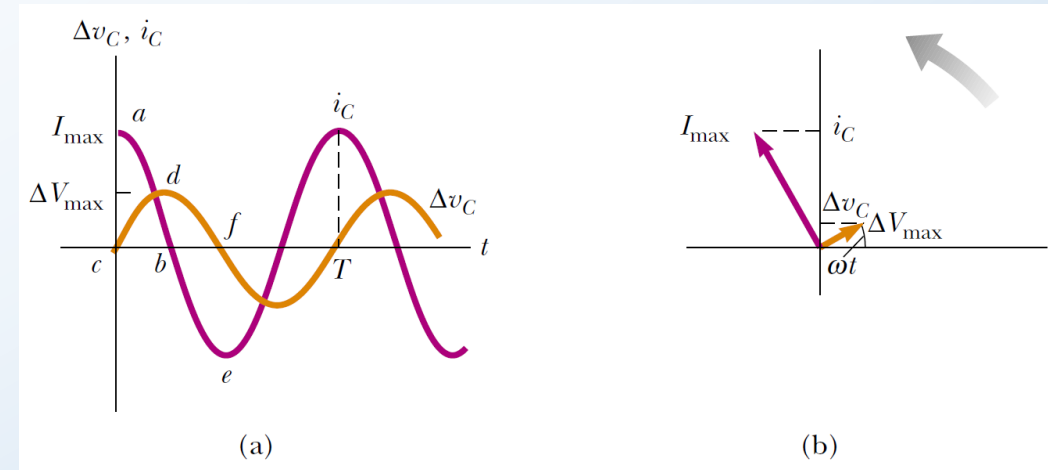

(a) Plots of the instantaneous current i_C and instantaneous voltage Δv_C across a capacitor as functions of time. The voltage lags behind the current by 90° . (b) Phasor diagram for the capacitive circuit, showing that the current leads the voltage by 90° .

- For a given applied voltage, as ω of the voltage source increases, the capacitive reactance decreases and therefore the maximum current increases.
- Again, note that the frequency of the current is determined by the frequency of the voltage source driving the circuit.
- As the frequency approaches zero, the capacitive reactance approaches infinity, and hence the current approaches zero.
- This makes sense because the circuit approaches direct current conditions as ω approaches zero, and the capacitor represents an open circuit.

Quick Quiz 33.6 Consider the AC circuit in the following figure. The frequency of the AC source is adjusted while its voltage amplitude is held constant. The lightbulb will glow the brightest at:

- (a) high frequencies.
- (b) low frequencies.
- (c) The brightness will be same at all frequencies.

Answer (b). For low frequencies, the reactance of the capacitor is large so that very little current exists in the capacitor branch. The reactance of the inductor is small so that current exists in the inductor branch and the lightbulb glows. As the frequency increases, the inductive reactance increases and the capacitive reactance decreases. At high frequencies, more current exists in the capacitor branch than the inductor branch and the lightbulb glows more dimly.

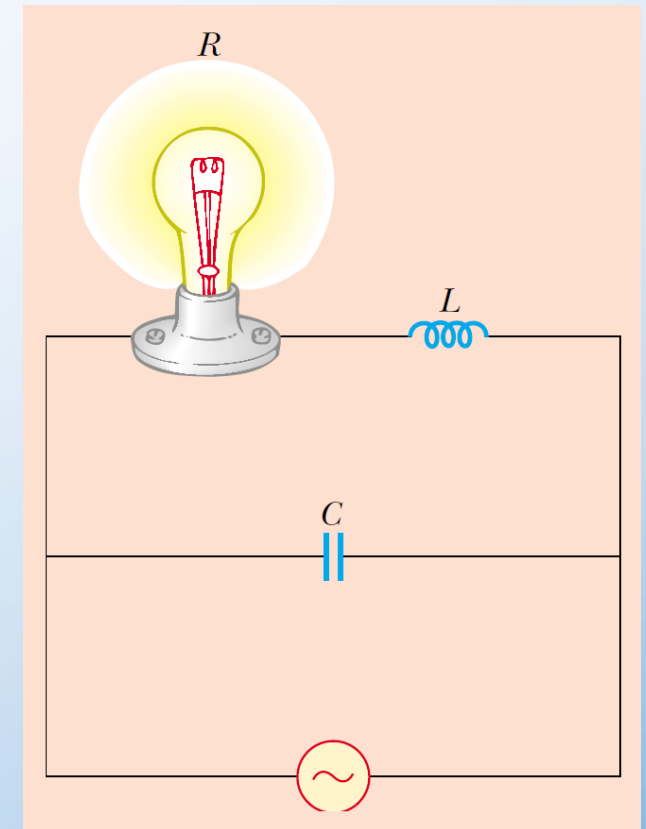



Example 33.03

An $8.00 - \mu\text{F}$ capacitor is connected to the terminals of a $60.0 - \text{Hz}$ AC source whose rms voltage is 150 V . Find the capacitive reactance and the rms current in the circuit.

$$X_C = \frac{1}{\omega C} = \frac{1}{2\pi f C} = \frac{1}{2 \times \pi \times 60.0 \times 8.00 \times 10^{-6}} = 332 \Omega$$

The rms current is:

$$I_{rms} = \frac{\Delta V_{C,rms}}{X_C} = \frac{150}{332} = 0.452 \text{ A}$$

What If? What if the frequency is doubled? What happens to the rms current in the circuit?

Answer If the frequency increases, the capacitive reactance decreases—just the opposite as in the case of an inductor. The decrease in capacitive reactance results in an increase in the current. Let us calculate the new capacitive reactance:

$$X_C = \frac{1}{\omega C} = \frac{1}{2\pi f C} = \frac{1}{2 \times \pi \times 120.0 \times 8.00 \times 10^{-6}} = 166 \Omega$$

The new rms current is:

$$I_{rms} = \frac{\Delta V_{C,rms}}{X_C} = \frac{150}{166} = 0.904 \text{ A}$$



Problem 33.17

What maximum current is delivered by an AC source with $\Delta V_{max} = 48.0$ V and $f = 90.0$ Hz when connected across a 3.70 – μF capacitor?

$$X_C = \frac{1}{\omega C} = \frac{1}{2\pi f C} = \frac{1}{2 \times \pi \times 90.0 \times 3.70 \times 10^{-6}} = 478 \Omega$$

The maximum current is:

$$I_{max} = \frac{\Delta V_{C,max}}{X_C} = \frac{48.0}{478} = 0.100 \text{ A} = 100 \text{ mA}$$

- Fig. (a) shows a circuit that contains a resistor, an inductor, and a capacitor connected in series across an alternating voltage source.
- As before, we assume that the applied voltage varies sinusoidally with time. It is convenient to assume that the instantaneous applied voltage is given by:

$$\Delta v = \Delta V_{max} \sin \omega t$$

- While the current varies as:

$$i = I_{max} \sin(\omega t - \phi)$$

- Where ϕ is some **phase angle** between the current and the applied voltage.
- The current will generally not be in phase with the voltage in an *RLC* circuit. **Our aim is to determine ϕ and I_{max} .**
- Fig. (b) shows the voltage versus time across each element in the circuit and their phase relationships.
- Because the elements are in series, the current everywhere in the circuit must be the same at any instant.
- That is, **the current at all points in a series AC circuit has the same amplitude and phase.**
- Therefore, the voltage across each element has a different amplitude and phase.

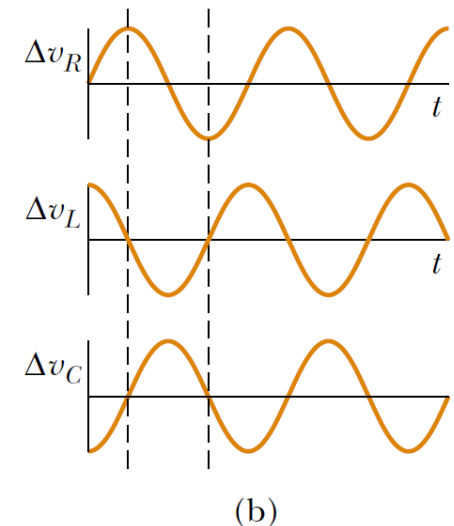
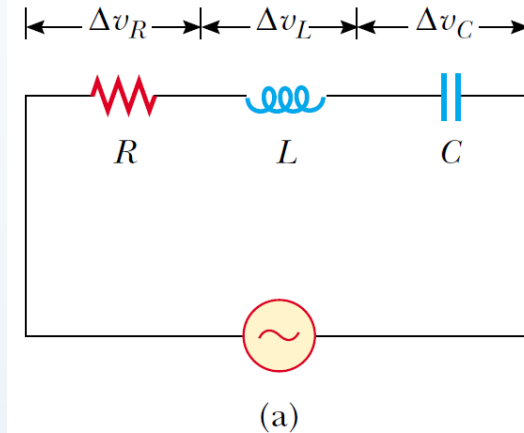

(a) A series circuit consisting of a resistor, an inductor, and a capacitor connected to an AC source. (b) Phase relationships for instantaneous voltages in the series *RLC* circuit.

- In particular, the voltage across the resistor is in phase with the current, the voltage across the inductor leads the current by 90° , and the voltage across the capacitor lags behind the current by 90° .
- Using these phase relationships, we can express the instantaneous voltages across the three circuit elements as:

$$\Delta v_R = I_{max} R \sin \omega t = \Delta V_R \sin \omega t$$

$$\Delta v_L = I_{max} X_L \sin \left(\omega t + \frac{\pi}{2} \right) = \Delta V_L \cos \omega t$$

$$\Delta v_C = I_{max} X_C \sin \left(\omega t - \frac{\pi}{2} \right) = -\Delta V_C \cos \omega t$$

- Where ΔV_R , ΔV_L , and ΔV_C are the maximum voltage values across the elements:

$$\Delta V_R = I_{max} R \quad \Delta V_L = I_{max} X_L \quad \Delta V_C = I_{max} X_C$$

- At this point, we could proceed by noting that the instantaneous voltage Δv across the three elements equals the sum:

$$\Delta v = \Delta v_R + \Delta v_L + \Delta v_C$$

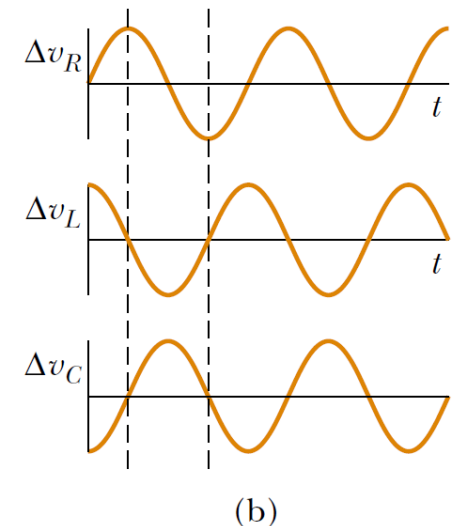
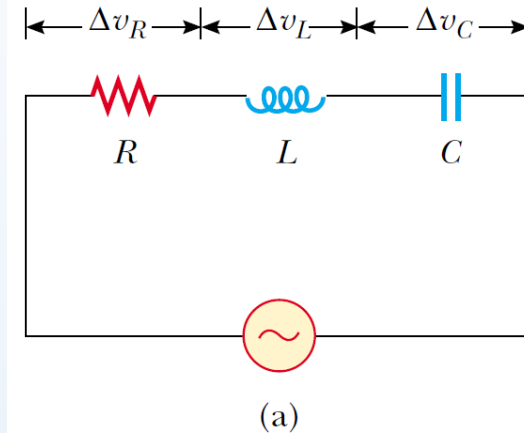

(a) A series circuit consisting of a resistor, an inductor, and a capacitor connected to an AC source. (b) Phase relationships for instantaneous voltages in the series RLC circuit.



- It is simpler to obtain the sum by examining the phasor diagram (upper Fig.).
- Because the current at any instant is the same in all elements, we combine the three phasor pairs to obtain (lower Fig.), in which a single phasor I_{max} is used to represent the current in each element.
- The vector sum of the voltage amplitudes ΔV_R , ΔV_L , and ΔV_C equals a phasor whose length is the maximum applied voltage ΔV_{max} , and which makes an angle ϕ with the current phasor I_{max} .
- The magnitude of the maximum applied voltage is:

$$\Delta V_{max} = \sqrt{\Delta V_R^2 + (\Delta V_L - \Delta V_C)^2} = \sqrt{(I_{max}R)^2 + (I_{max}X_L - I_{max}X_C)^2}$$

$$\Delta V_{max} = I_{max}\sqrt{R^2 + (X_L - X_C)^2} = I_{max}Z$$

- Where Z is called the **impedance** of the circuit and plays the role of resistance. Therefore, impedance also has units of ohms.

$$Z \equiv \sqrt{R^2 + (X_L - X_C)^2}$$

- Therefore, we can express the maximum current as:

$$I_{max} = \frac{\Delta V_{max}}{\sqrt{R^2 + (X_L - X_C)^2}} = \frac{\Delta V_{max}}{Z}$$

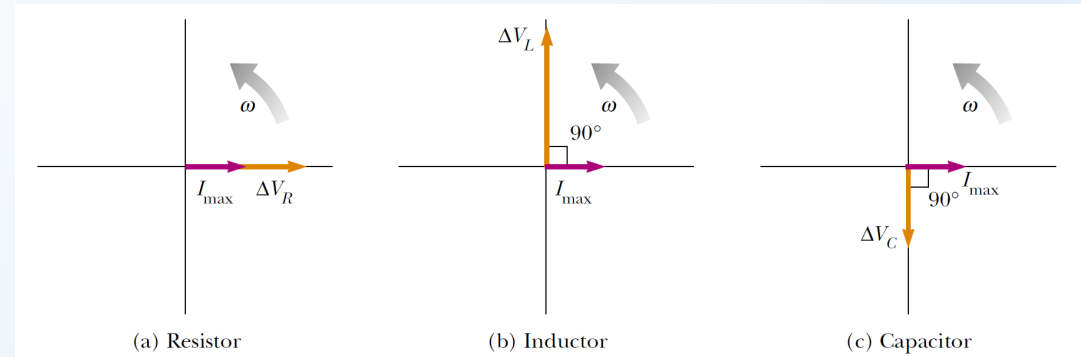

Phase relationships between the voltage and current phasors for (a) a resistor, (b) an inductor, and (c) a capacitor connected in series.

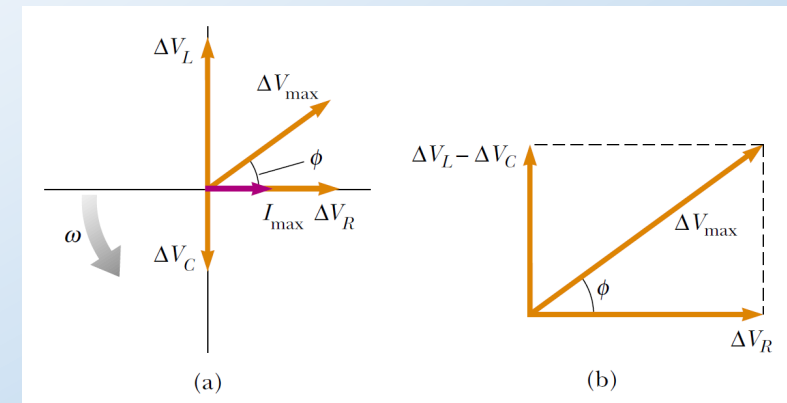

(a) Phasor diagram for the series RLC circuit shown in Figure 33.13a. The phasor ΔV_R is in phase with the current phasor I_{max} , the phasor ΔV_L leads I_{max} by 90° , and the phasor ΔV_C lags I_{max} by 90° . The total voltage ΔV_{max} makes an angle ϕ with I_{max} . (b) Simplified version of the phasor diagram shown in part (a).



- Note that the impedance and therefore the current in an AC circuit depend upon the resistance, the inductance, the capacitance, and the frequency (because the reactances are frequency-dependent).
- By removing the common factor I_{max} from each phasor in the previous Fig., we can construct the impedance triangle. From this phasor diagram we find that the phase angle ϕ between the current and the voltage is:

$$\phi = \tan^{-1} \left(\frac{X_L - X_C}{R} \right) = \cos^{-1} \left(\frac{R}{Z} \right) = \sin^{-1} \left(\frac{X_L - X_C}{Z} \right)$$

- When $X_L > X_C$ (which occurs at high frequencies), the phase angle is positive, signifying that the current lags behind the applied voltage, and the circuit is more inductive than capacitive.
- When $X_L < X_C$, the phase angle is negative, signifying that the current leads the applied voltage, and the circuit is more capacitive than inductive.
- When $X_L = X_C$, the phase angle is zero and the circuit is purely resistive.

Quick Quiz 33.7 Label each part of Figure 33.17 as being $X_L > X_C$, $X_L = X_C$, $X_L < X_C$.

Answer (a) $X_L < X_C$, (b) $X_L = X_C$, and (c) $X_L > X_C$.

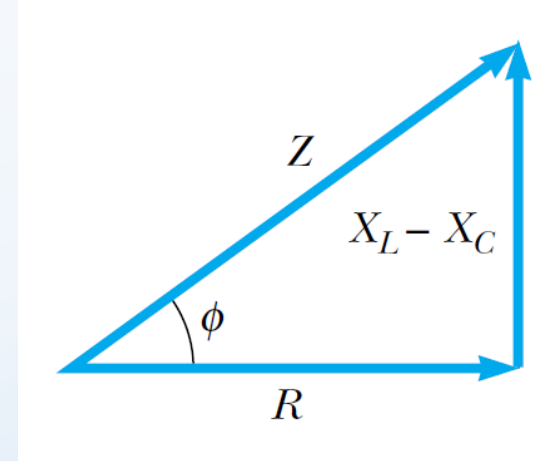



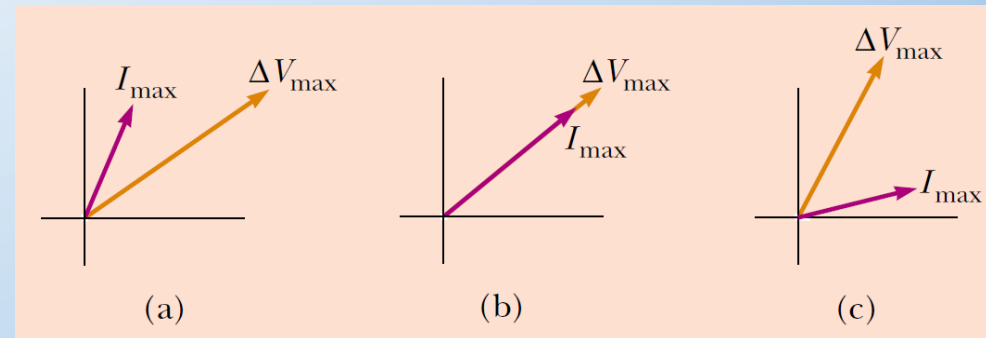



An impedance triangle for a series RLC circuit gives the relationship $Z = \sqrt{R^2 + (X_L - X_C)^2}$.

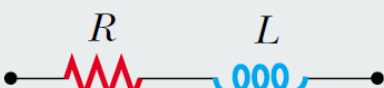

Match the phasor diagrams to the relationships between the reactances.

Impedance Values and Phase Angles for Various Circuit-Element Combinations^a

Circuit Elements	Impedance Z	Phase Angle ϕ
	R	0°
	X_C	-90°
	X_L	$+90^\circ$
	$\sqrt{R^2 + X_C^2}$	Negative, between -90° and 0°
	$\sqrt{R^2 + X_L^2}$	Positive, between 0° and 90°
	$\sqrt{R^2 + (X_L - X_C)^2}$	Negative if $X_C > X_L$ Positive if $X_C < X_L$

^aIn each case, an AC voltage (not shown) is applied across the elements.



Example 33.05

A series *RLC* AC circuit has $R = 425 \Omega$, $L = 1.25 \text{ H}$, $C = 3.50 \mu\text{F}$, $\omega = 377 \text{ s}^{-1}$, and $\Delta V_{max} = 150 \text{ V}$. (a) Determine the inductive reactance, the capacitive reactance, and the impedance of the circuit. (b) Find the maximum current in the circuit. (c) Find the phase angle between the current and voltage. (d) Find both the maximum voltage and the instantaneous voltage across each element.

(a) The reactances are:

$$X_L = \omega L = 377 \times 1.25 = 471 \Omega$$

$$X_C = \frac{1}{\omega C} = \frac{1}{377 \times 3.50 \times 10^{-6}} = 758 \Omega$$

The impedance is:

$$Z = \sqrt{R^2 + (X_L - X_C)^2} = \sqrt{(425)^2 + (471 - 758)^2} = 513 \Omega$$

$$(b) I_{max} = \frac{\Delta V_{max}}{Z} = \frac{150}{513} = 0.292 \text{ A}$$

$$(c) \phi = \tan^{-1} \left(\frac{X_L - X_C}{R} \right) = \tan^{-1} \left(\frac{471 - 758}{425} \right) = -34.0^\circ$$

Because the capacitive reactance is larger than the inductive reactance, the circuit is more capacitive than inductive. In this case, the phase angle ϕ is negative and the current leads the applied voltage.



Example 33.05

A series *RLC* AC circuit has $R = 425 \Omega$, $L = 1.25 \text{ H}$, $C = 3.50 \mu\text{F}$, $\omega = 377 \text{ s}^{-1}$, and $\Delta V_{max} = 150 \text{ V}$. (a) Determine the inductive reactance, the capacitive reactance, and the impedance of the circuit. (b) Find the maximum current in the circuit. (c) Find the phase angle between the current and voltage. (d) Find both the maximum voltage and the instantaneous voltage across each element.

(d) The maximum voltages are:

$$\Delta V_R = I_{max} R = 0.292 \times 425 = 124 \text{ V}$$

$$\Delta V_L = I_{max} X_L = 0.292 \times 471 = 138 \text{ V}$$

$$\Delta V_C = I_{max} X_C = 0.292 \times 758 = 221 \text{ V}$$

The instantaneous voltages across the three elements are:

$$\Delta v_R = (124 \text{ V}) \sin 377t$$

$$\Delta v_L = (138 \text{ V}) \cos 377t$$

$$\Delta v_C = (-221 \text{ V}) \cos 377t$$



Example 33.05

A series RLC AC circuit has $R = 425 \Omega$, $L = 1.25 \text{ H}$, $C = 3.50 \mu\text{F}$, $\omega = 377 \text{ s}^{-1}$, and $\Delta V_{max} = 150 \text{ V}$. (a) Determine the inductive reactance, the capacitive reactance, and the impedance of the circuit. (b) Find the maximum current in the circuit. (c) Find the phase angle between the current and voltage. (d) Find both the maximum voltage and the instantaneous voltage across each element.

What If? What if you added up the maximum voltages across the three circuit elements? Is this a physically meaningful quantity?

Answer The sum of the maximum voltages across the elements is $\Delta V_R + \Delta V_L + \Delta V_C = 484 \text{ V}$. Note that this sum is much greater than the maximum voltage of the source, 150 V . The sum of the maximum voltages is a meaningless quantity because when sinusoidally varying quantities are added, both their amplitudes and their phases must be taken into account. We know that the maximum voltages across the various elements occur at different times. That is, the voltages must be added in a way that takes account of the different phases.



Problem 33.21

Additional problem

A series AC circuit contains the following components: $R = 150 \Omega$, $L = 250 \text{ mH}$, $C = 2.00 \mu\text{F}$ and a source with $\Delta V_{max} = 210 \text{ V}$ operating at 50.0 Hz . Calculate the (a) inductive reactance, (b) capacitive reactance, (c) impedance, (d) maximum current, and (e) phase angle between current and source voltage.

$$(a) X_L = \omega L = 2\pi fL = 2 \times \pi \times 50.0 \times 250 \times 10^{-3} = 78.5 \Omega$$

$$(b) X_C = \frac{1}{\omega C} = \frac{1}{2\pi fC} = \frac{1}{2 \times \pi \times 50.0 \times 2.00 \times 10^{-6}} = 1591 \Omega = 1.591 \text{ k}\Omega$$

$$(c) Z = \sqrt{R^2 + (X_L - X_C)^2} = \sqrt{(150)^2 + (78.5 - 1591)^2} = 1520 \Omega = 1.520 \text{ k}\Omega$$

$$(d) I_{max} = \frac{\Delta V_{max}}{Z} = \frac{210}{1520} = 0.138 \text{ A} = 138 \text{ mA}$$

$$(e) \phi = \tan^{-1} \left(\frac{X_L - X_C}{R} \right) = \tan^{-1} \left(\frac{78.5 - 1591}{150} \right) = -84.3^\circ$$



Problem 33.22

Additional problem

A sinusoidal voltage $\Delta v(t) = (40.0 \text{ V}) \sin(100t)$ is applied to a series RLC circuit with $L = 160 \text{ mH}$, $C = 99.0 \mu\text{F}$, and $R = 68.0 \Omega$. (a) What is the impedance of the circuit? (b) What is the maximum current? (c) Determine the numerical values for I_{max} , ω , and ϕ in the equation $i(t) = I_{max} \sin(\omega t - \phi)$.

$$(a) \quad X_L = \omega L = 100 \times 160 \times 10^{-3} = 16.0 \Omega$$

$$X_C = \frac{1}{\omega C} = \frac{1}{100 \times 99.0 \times 10^{-6}} = 101.0 \Omega$$

$$Z = \sqrt{R^2 + (X_L - X_C)^2} = \sqrt{(68.0)^2 + (16.0 - 101.0)^2} = 109.0 \Omega$$

$$(b) \quad I_{max} = \frac{\Delta V_{max}}{Z} = \frac{40.0}{109.0} = 0.367 \text{ A} = 367 \text{ mA}$$

$$(c) \quad I_{max} = 0.367 \text{ A}$$

$$\omega = 100.0 \text{ rad/s}$$

$$\phi = \tan^{-1} \left(\frac{X_L - X_C}{R} \right) = \tan^{-1} \left(\frac{16.0 - 101.0}{68.0} \right) = -51.3^\circ$$

Problem 33.26

Additional problem

An AC source with $\Delta V_{max} = 150 \text{ V}$ and $f = 50.0 \text{ Hz}$ is connected between points a and d in the following figure. Calculate the maximum voltages between points (a) a and b , (b) b and c , (c) c and d , and (d) b and d .

$$X_L = \omega L = 2\pi fL = 2 \times \pi \times 50.0 \times 185 \times 10^{-3} = 58.1 \Omega$$

$$X_C = \frac{1}{\omega C} = \frac{1}{2\pi fC} = \frac{1}{2 \times \pi \times 50.0 \times 65.0 \times 10^{-6}} = 49.0 \Omega$$

$$Z = \sqrt{R^2 + (X_L - X_C)^2} = \sqrt{(40.0)^2 + (58.1 - 49.0)^2} = 41.0 \Omega$$

$$I_{max} = \frac{\Delta V_{max}}{Z} = \frac{150}{41.0} = 3.66 \text{ A}$$

$$(a) \Delta V_R = I_{max}R = 3.66 \times 40.0 = 146.4 \text{ V}$$

$$(b) \Delta V_L = I_{max}X_L = 3.66 \times 58.1 = 212.65 \text{ V}$$

$$(c) \Delta V_C = I_{max}X_C = 3.66 \times 49.0 = 179.34 \text{ V}$$

$$(d) \Delta V_L - \Delta V_C = 212.65 - 179.34 = 33.31 \text{ V}$$

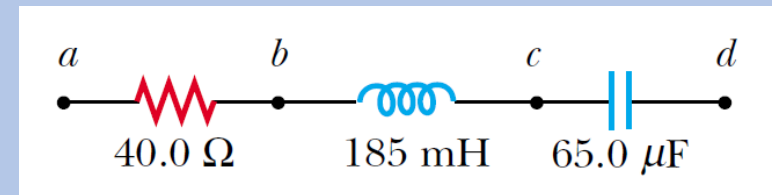

- The power delivered by a battery to a DC circuit is equal to the product of the current and the emf of the battery.
- Likewise, the instantaneous power delivered by an AC source to a circuit is the product of the source current and the applied voltage.

- For the *RLC* circuit shown in Fig. (a), we can express the instantaneous power \mathcal{P} As:

$$\mathcal{P} = i\Delta v = I_{max} \sin(\omega t - \phi) \Delta V_{max} \sin \omega t = I_{max} \Delta V_{max} \sin \omega t \sin(\omega t - \phi)$$

- By using the trigonometric identity $\sin(\omega t - \phi) = \sin \omega t \cos \phi - \cos \omega t \sin \phi$, we obtain:

$$\mathcal{P} = I_{max} \Delta V_{max} \sin^2 \omega t \cos \phi - I_{max} \Delta V_{max} \sin \omega t \cos \omega t \sin \phi$$

- The time average of \mathcal{P} over one or more cycles, noting that I_{max} , ΔV_{max} , ϕ and ω are all constants, gives:

$$\mathcal{P}_{av} = \frac{1}{2} I_{max} \Delta V_{max} \cos \phi$$

- Where \mathcal{P}_{av} is the **average power**. It is convenient to express the average power in terms of the rms current and rms voltage:

$$\mathcal{P}_{av} = I_{rms} \Delta V_{rms} \cos \phi$$

- Where the quantity $\cos \phi$ is called the **power factor**.

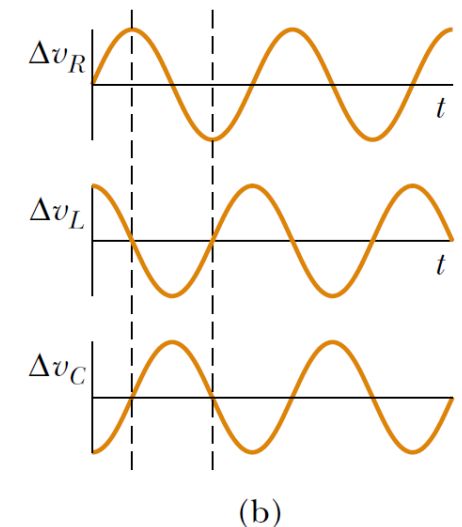
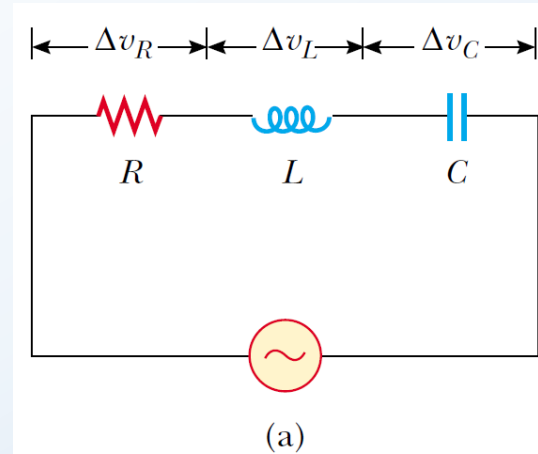

(a) A series circuit consisting of a resistor, an inductor, and a capacitor connected to an AC source. (b) Phase relationships for instantaneous voltages in the series *RLC* circuit.

- By inspecting Fig. (b), we see that the maximum voltage across the resistor is given by $\Delta V_R = \Delta V_{max} \cos \phi = I_{max}R$.
- Using the fact that $\Delta V_{rms} = \Delta V_{max}/\sqrt{2}$ and $\cos \phi = I_{max}R/\Delta V_{max}$, we find that we can express \mathcal{P}_{av} as:

$$\mathcal{P}_{av} = I_{rms} \Delta V_{rms} \cos \phi = I_{rms} \left(\frac{\Delta V_{max}}{\sqrt{2}} \right) \frac{I_{max}R}{\Delta V_{max}} = I_{rms} \frac{I_{max}R}{\sqrt{2}}$$

- After making the substitution $I_{rms} = I_{max}/\sqrt{2}$, we have:

$$\mathcal{P}_{av} = I_{rms}^2 R$$

- In words, **the average power delivered by the source is converted to internal energy in the resistor**, just as in the case of a DC circuit.
- We find that **no power losses are associated with pure capacitors and pure inductors in an AC circuit**.

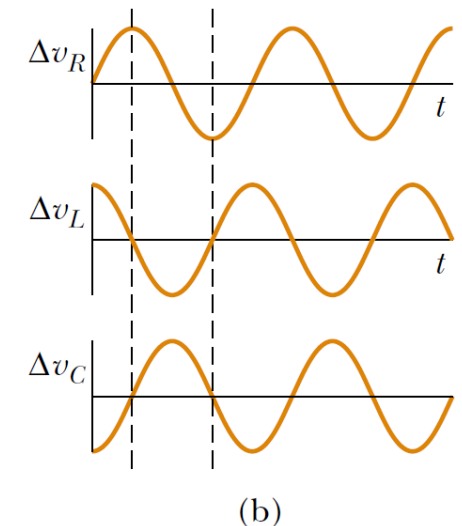
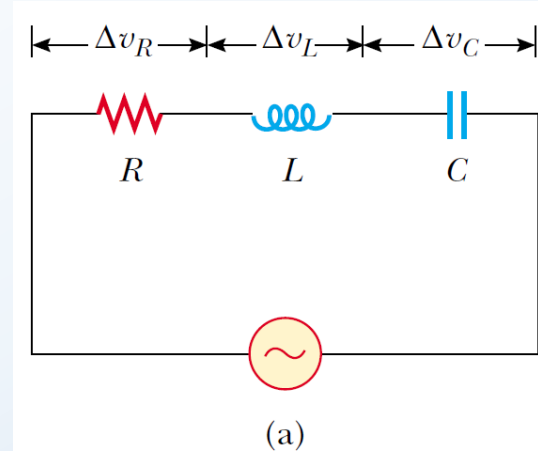

(a) A series circuit consisting of a resistor, an inductor, and a capacitor connected to an AC source. (b) Phase relationships for instantaneous voltages in the series *RLC* circuit.



Example 33.06

A series RLC AC circuit has $R = 425 \Omega$, $L = 1.25 \text{ H}$, $C = 3.50 \mu\text{F}$, $\omega = 377 \text{ s}^{-1}$, and $\Delta V_{max} = 150 \text{ V}$. (a) Determine the inductive reactance, the capacitive reactance, and the impedance of the circuit. (b) Find the maximum current in the circuit. (c) Find the phase angle between the current and voltage. (d) Find the average power delivered to the circuit.

(a) The reactances are:

$$X_L = \omega L = 377 \times 1.25 = 471 \Omega$$

$$X_C = \frac{1}{\omega C} = \frac{1}{377 \times 3.50 \times 10^{-6}} = 758 \Omega$$

The impedance is:

$$Z = \sqrt{R^2 + (X_L - X_C)^2} = \sqrt{(425)^2 + (471 - 758)^2} = 513 \Omega$$

$$(b) I_{max} = \frac{\Delta V_{max}}{Z} = \frac{150}{513} = 0.292 \text{ A}$$

$$(c) \phi = \tan^{-1} \left(\frac{X_L - X_C}{R} \right) = \tan^{-1} \left(\frac{471 - 758}{425} \right) = -34.0^\circ$$

Because the capacitive reactance is larger than the inductive reactance, the circuit is more capacitive than inductive. In this case, the phase angle ϕ is negative and the current leads the applied voltage.



Example 33.06

A series RLC AC circuit has $R = 425 \Omega$, $L = 1.25 \text{ H}$, $C = 3.50 \mu\text{F}$, $\omega = 377 \text{ s}^{-1}$, and $\Delta V_{max} = 150 \text{ V}$. (a) Determine the inductive reactance, the capacitive reactance, and the impedance of the circuit. (b) Find the maximum current in the circuit. (c) Find the phase angle between the current and voltage. (d) Find the average power delivered to the circuit.

(d) The average power delivered is:

$$\mathcal{P}_{av} = \frac{1}{2} I_{max} \Delta V_{max} \cos \phi = \frac{1}{2} \times 0.292 \times 150 \times \cos(-34.0) = 18.2 \text{ W}$$

We can obtain the same result using $\mathcal{P}_{av} = I_{rms}^2 R$.



A series RLC circuit has a resistance of 45.0Ω and an impedance of 75.0Ω . What average power is delivered to this circuit when $\Delta V_{rms} = 210 \text{ V}$?

$$I_{rms} = \frac{\Delta V_{rms}}{Z} = \frac{210}{75.0} = 2.80 \text{ A}$$

$$\mathcal{P}_{av} = I_{rms}^2 R = (2.80)^2 \times 45.0 = 353 \text{ W}$$



Problem 33.33

In a certain series RLC circuit, $I_{rms} = 9.00$ A, $\Delta V_{rms} = 180$ V, and the current leads the voltage by 37.0° . (a) What is the total resistance of the circuit? (b) Calculate the reactance of the circuit ($X_L - X_C$).

$$(a) \mathcal{P}_{av} = I_{rms} \Delta V_{rms} \cos \phi = I_{rms}^2 R$$

$$R = \frac{\Delta V_{rms} \cos \phi}{I_{rms}} = \frac{180 \times \cos(-37.0)}{9.00} = 16.0 \Omega$$

$$(b) \tan \phi = \frac{X_L - X_C}{R}$$

$$X_L - X_C = R \tan \phi = 16.0 \times \tan(-37.0) = -12.0 \Omega$$



- A series *RLC* circuit is said to be **in resonance** when the current has its maximum value.
- In general, the rms current can be written:

$$I_{rms} = \frac{\Delta V_{rms}}{Z} = \frac{\Delta V_{rms}}{\sqrt{R^2 + (X_L - X_C)^2}}$$

- Because the impedance Z depends on the frequency of the source, the current in the *RLC* circuit also depends on the frequency.
- The frequency ω_0 at which $X_L - X_C = 0$ is called the **resonance frequency** of the circuit.
- To find ω_0 , we use the condition $X_L = X_C$, from which we obtain $\omega_0 L = 1/\omega_0 C$, or:

$$\omega_0 = \frac{1}{\sqrt{LC}}$$

- The current in a series *RLC* circuit reaches its maximum value when the frequency of the applied voltage matches the resonance frequency—which depends only on L and C .
- Furthermore, at this frequency the current is in phase with the applied voltage.

Quick Quiz 33.9 The impedance of a series *RLC* circuit at resonance is:

- (a) larger than R (b) less than R (c) equal to R (d) impossible to determine.



Example 33.07

Additional example

Consider a series RLC circuit for which $R = 150 \Omega$, $L = 20.0 \text{ mH}$, $\Delta V_{rms} = 20.0 \text{ V}$, and $\omega = 5000 \text{ s}^{-1}$. Determine the value of the capacitance for which the current is a maximum.

The current has its maximum value at the resonance frequency ω_0 , which should be made to match the “driving” frequency of 5000 s^{-1} :

$$\omega_0 = \frac{1}{\sqrt{LC}}$$

$$C = \frac{1}{\omega_0^2 L} = \frac{1}{(5000)^2 \times 20.0 \times 10^{-3}} = 2.00 \times 10^{-6} \text{ F} = 2.00 \mu\text{F}$$



Problem 33.37

An *RLC* circuit is used in a radio to tune into an FM station broadcasting at 99.7 MHz. The resistance in the circuit is 12.0Ω , and the inductance is $1.40 \mu\text{H}$. What capacitance should be used?

$$\omega_0 = \frac{1}{\sqrt{LC}}$$

$$C = \frac{1}{\omega_0^2 L} = \frac{1}{(2\pi f)^2 L} = \frac{1}{(2 \times \pi \times 99.7 \times 10^6)^2 \times 1.40 \times 10^{-6}} = 1.82 \times 10^{-12} \text{ F} = 1.82 \text{ pF}$$