

Chapter 8

Potential Energy



Potential energy of a system

Potential energy can be considered as stored energy in an object .

Gravitational potential energy is due to gravity field

Example: Book – Earth system:

The book is slowly moved from A to B. (i.e. kinetic Energy at A and B are zero).

The work done by external applied force (directed upwards opposite to mg) is

$$W = (\mathbf{F}_{\text{app}}) \cdot \Delta \mathbf{r} = (mg\hat{\mathbf{j}}) \cdot [(y_b - y_a)\hat{\mathbf{j}}] = mgy_b - mgy_a$$

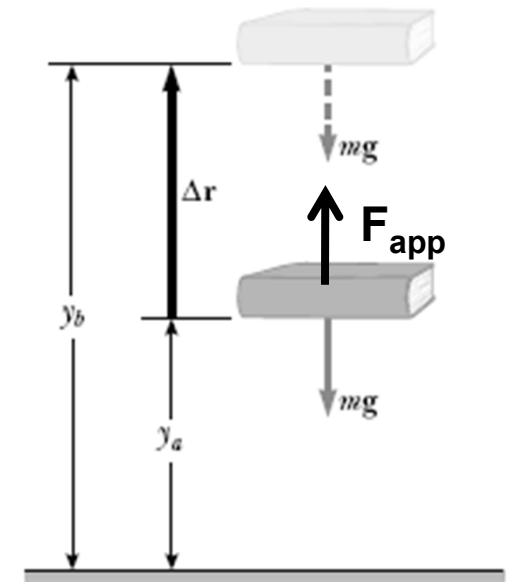

$$U_g \equiv mgy$$

Note: gravitational energy depends on difference in elevation

Work done by gravity force

Focus on the work done by gravity force only as it falls from point B to A

$$W_{\text{on book}} = (m\mathbf{g}) \cdot \Delta\mathbf{r} = (-mg\hat{\mathbf{j}}) \cdot [(y_a - y_b)\hat{\mathbf{j}}] = mgy_b - mgy_a$$

$$W_{\text{on book}} = \Delta K_{\text{book}}$$

$$\Delta K_{\text{book}} = mgy_b - mgy_a$$

$$mgy_b - mgy_a = -(mgy_a - mgy_b) = -(U_f - U_i) = -\Delta U_g$$

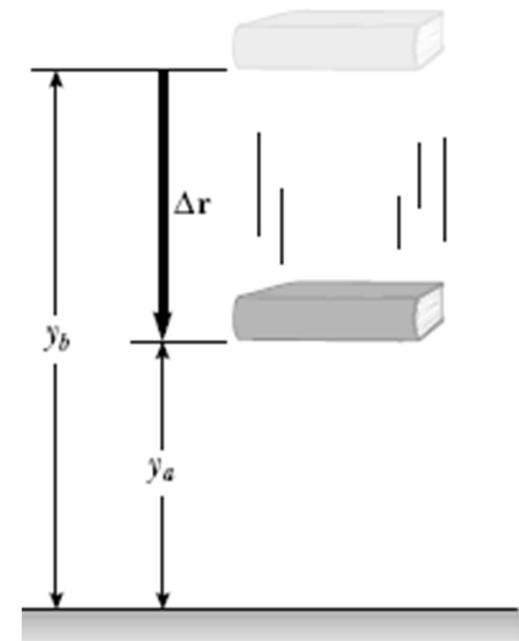

Mechanical energy

$$E_{\text{mech}} = K + U_g$$

$$(K_f - K_i) + (U_f - U_i) = 0$$

$$K_f + U_f = K_i + U_i$$

The above equations assume change kinetic and potential energy of the system.

No external forces acting on the system.

Elastic Potential Energy

$$W_{F_{\text{app}}} = \frac{1}{2}kx_f^2 - \frac{1}{2}kx_i^2$$

$$U_s \equiv \frac{1}{2}kx^2.$$

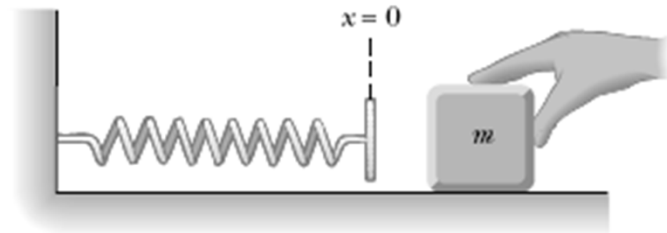

(a)

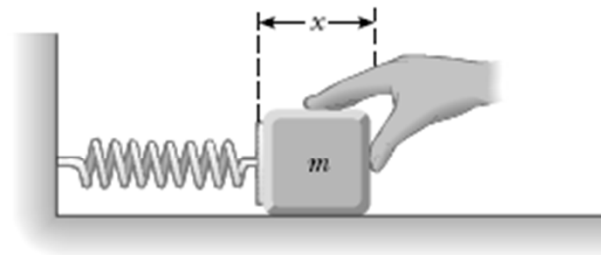

$$U_s = \frac{1}{2}kx^2$$
$$K_i = 0$$

(b)

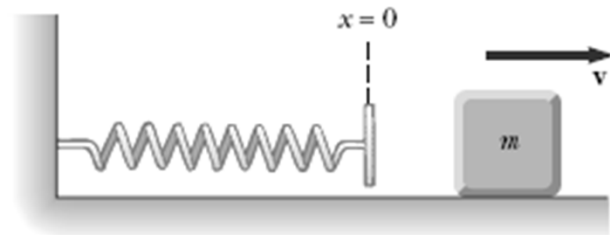

$$U_s = 0$$
$$K_f = \frac{1}{2}mv^2$$

(c)

Example

A ball of mass m is dropped from a height h above the ground, as shown in Figure 8.6.

(A) Neglecting air resistance, determine the speed of the ball when it is at a height y above the ground.

(B) Determine the speed of the ball at y if at the instant of release it already has an initial upward speed v_i at the initial altitude h .

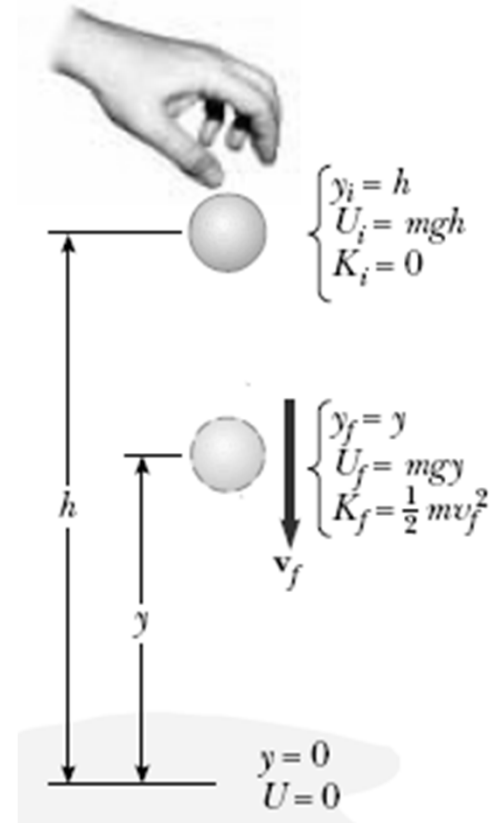

$$K_f + U_f = K_i + U_i$$

$$\frac{1}{2}mv_f^2 + mgy = 0 + mgh$$

$$v_f^2 = 2g(h - y)$$

$$v_f = \sqrt{2g(h - y)}$$

$$\frac{1}{2}mv_f^2 + mgy = \frac{1}{2}mv_i^2 + mgh$$

$$v_f^2 = v_i^2 + 2g(h - y)$$

$$v_f = \sqrt{v_i^2 + 2g(h - y)}$$

Example

A pendulum consists of a sphere of mass m attached to a light cord of length L , as shown in Figure 8.7. The sphere is released from rest at point **(A)** when the cord makes an angle θ_A with the vertical, and the pivot at P is frictionless.

(A) Find the speed of the sphere when it is at the lowest point **(B)**.

(B) What is the tension T_B in the cord at **(B)**?

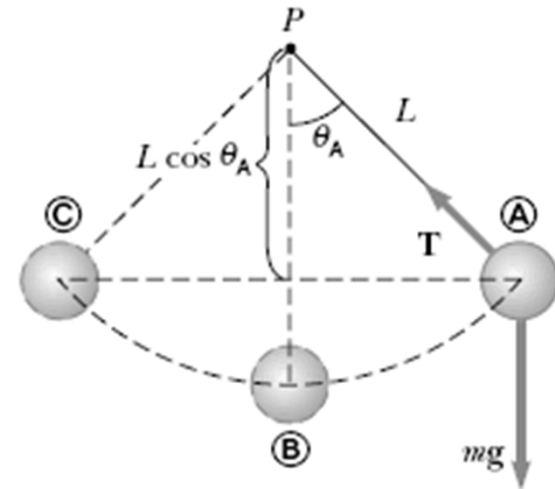

$$K_B + U_B = K_A + U_A$$

$$\frac{1}{2}mv_B^2 - mgL = 0 - mgL \cos \theta_A$$

$$(1) \quad v_B = \sqrt{2gL(1 - \cos \theta_A)}$$

$$(2) \quad \sum F_r = mg - T_B = ma_r = -m \frac{v_B^2}{L}$$

$$(3) \quad T_B = mg + 2mg(1 - \cos \theta_A) = mg(3 - 2 \cos \theta_A)$$

Example

The launching mechanism of a toy gun consists of a spring of unknown spring constant (Fig. 8.9a). When the spring is compressed 0.120 m, the gun, when fired vertically, is able to launch a 35.0-g projectile to a maximum height of 20.0 m above the position of the projectile before firing.

(A) Neglecting all resistive forces, determine the spring constant.

(B) Find the speed of the projectile as it moves through the equilibrium position of the spring (where $x_B = 0.120$ m) as shown in Figure 8.9b.

© $x_C = 20.0$ m

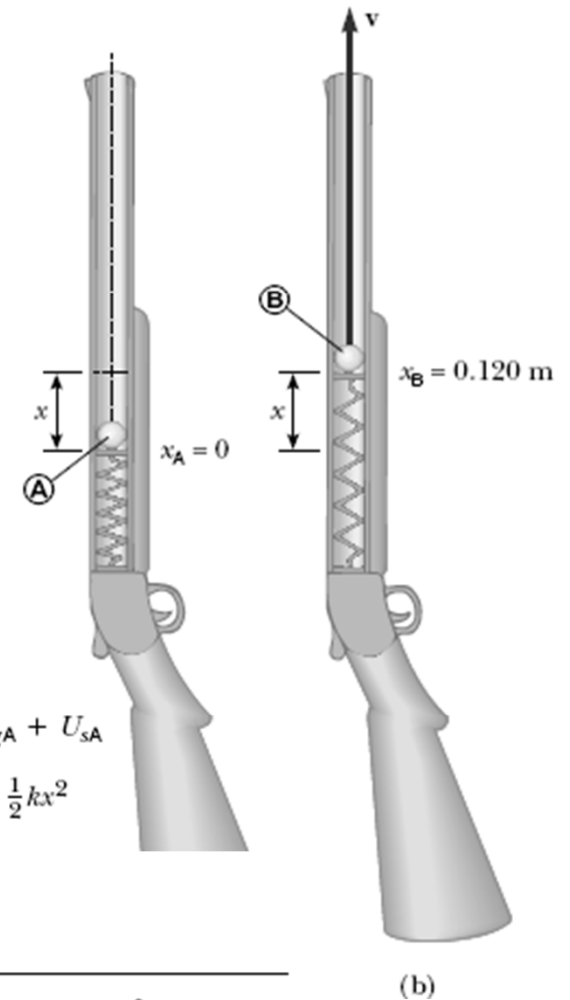

$$E_C = E_A$$

$$K_C + U_{gC} + U_{sC} = K_A + U_{gA} + U_{sA}$$

$$0 + mgh + 0 = 0 + 0 + \frac{1}{2}kx^2$$

$$k = \frac{2mgh}{x^2} = \frac{2(0.0350 \text{ kg})(9.80 \text{ m/s}^2)(20.0 \text{ m})}{(0.120 \text{ m})^2}$$

$$= 953 \text{ N/m}$$

$$E_B = E_A$$

$$K_B + U_{gB} + U_{sB} = K_A + U_{gA} + U_{sA}$$

$$\frac{1}{2}mv_B^2 + mgx_B + 0 = 0 + 0 + \frac{1}{2}kx^2$$

$$v_B = \sqrt{\frac{kx^2}{m} - 2gx_B}$$

$$= \sqrt{\frac{(953 \text{ N/m})(0.120 \text{ m})^2}{(0.0350 \text{ kg})} - 2(9.80 \text{ m/s}^2)(0.120 \text{ m})}$$

$$= 19.7 \text{ m/s}$$

Example

The launching mechanism of a toy gun consists of a spring of unknown spring constant (Fig. 8.9a). When the spring is compressed 0.120 m, the gun, when fired vertically, is able to launch a 35.0-g projectile to a maximum height of 20.0 m above the position of the projectile before firing.

(A) Neglecting all resistive forces, determine the spring constant.

(B) Find the speed of the projectile as it moves through the equilibrium position of the spring (where $x_B = 0.120$ m) as shown in Figure 8.9b.

$$E_B = E_A$$

$$K_B + U_{gB} + U_{sB} = K_A + U_{gA} + U_{sA}$$

$$\frac{1}{2}mv_B^2 + mgx_B + 0 = 0 + 0 + \frac{1}{2}kx^2$$

$$v_B = \sqrt{\frac{kx^2}{m} - 2gx_B}$$

$$= \sqrt{\frac{(953 \text{ N/m})(0.120 \text{ m})^2}{(0.0350 \text{ kg})} - 2(9.80 \text{ m/s}^2)(0.120 \text{ m})}$$

$$= 19.7 \text{ m/s}$$

© $x_C = 20.0$ m

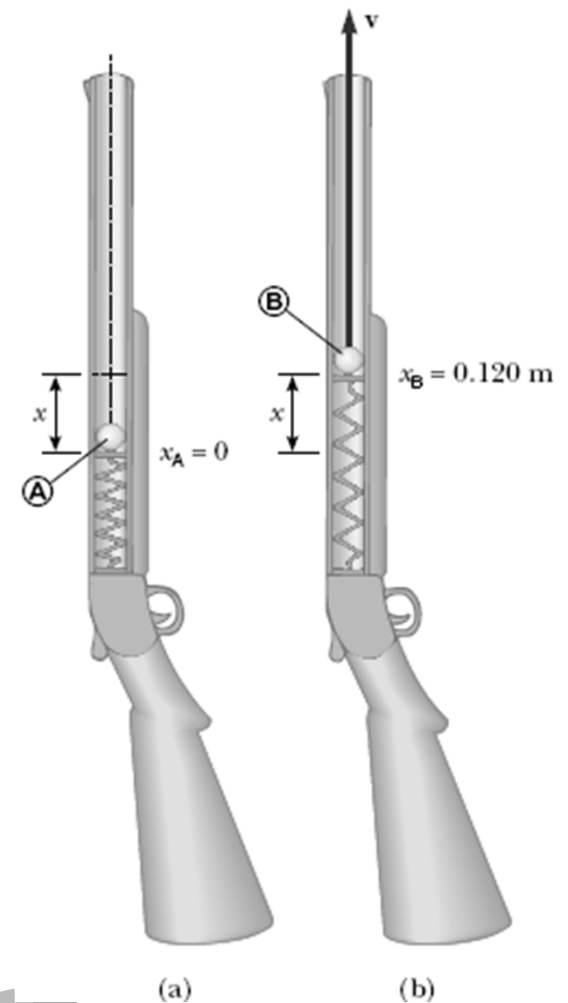

Conservative Vs Nonconservative forces

The work done by a Conservative force has the following properties:

- the work is independent of the path,
- and the work for closed path is zero.
- For example: gravity force, spring force.

Nonconservative force doesn't satisfy the above properties.

Nonconservative force cause change in mechanical energy.

Example: friction force

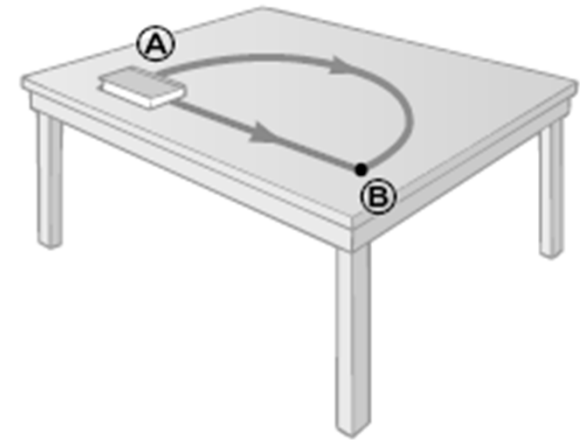

Changes in mechanical energy for nonconservative forces

The nonconservative force cause a change in mechanical energy. This change could be dissipated as heat due to temperature increase due to friction.

$$\Delta E_{\text{mech}} = \Delta K + \Delta U = -f_k d$$

That means the E_i do not equal E_f But $E_f - E_i = -f_k d$

Example

A 3.00-kg crate slides down a ramp. The ramp is 1.00 m in length and inclined at an angle of 30.0° , as shown in Figure 8.11. The crate starts from rest at the top, experiences a constant friction force of magnitude 5.00 N, and continues to move a short distance on the horizontal floor after it leaves the ramp. Use energy methods to determine the speed of the crate at the bottom of the ramp.

$$\begin{aligned} E_i &= K_i + U_i = 0 + U_i = mgy_i \\ &= (3.00 \text{ kg})(9.80 \text{ m/s}^2)(0.500 \text{ m}) = 14.7 \text{ J} \end{aligned}$$

$$E_f = K_f + U_f = \frac{1}{2}mv_f^2 + 0$$

$$(1) \quad -f_k d = (-5.00 \text{ N})(1.00 \text{ m}) = -5.00 \text{ J}$$

$$E_f - E_i = \frac{1}{2}mv_f^2 - mgy_i = -f_k d$$

$$(2) \quad \frac{1}{2}mv_f^2 = 14.7 \text{ J} - 5.00 \text{ J} = 9.70 \text{ J}$$

$$v_f^2 = \frac{19.4 \text{ J}}{3.00 \text{ kg}} = 6.47 \text{ m}^2/\text{s}^2$$

$$v_f = 2.54 \text{ m/s}$$

